



## **A GRID CONNECTED PV SYSTEM INTEGRATED THROUGH MULTILEVEL MODULAR CASCADED H-BRIDGE INVERTER BY USING FUZZY LOGIC CONTROLLER**

**P. Subrahmanyeswara Rao\*, A. Durga Bhavani\*\* & M. Rama Sisir\*\***

\* PG Scholar, Department of Electrical and Electronics Engineering, Pragati Engineering College, Surampalem, Andhra Pradesh

\*\* Assistant Professor, Department of Electrical and Electronics Engineering, Pragati Engineering College, Surampalem, Andhra Pradesh

### **Abstract:**

*This paper presents a modular cascaded H-bridge multilevel photovoltaic (PV) inverter for three-phase grid-connected applications. The modular cascaded multilevel topology helps to improve the efficiency and flexibility of PV systems. The main abstruse is the harmonization of the DG to the utility grid. Generally current regulated PWM voltage-source inverters (VSI) are used for synchronizing the utility grid with DG source in order to meet the following objectives: 1) To ensure grid stability 2) active and reactive power control through Fuzzy Logic and PI controller 3) power quality improvement (i.e. harmonic elimination) etc. For three-phase grid-connected applications, PV mismatches may introduce unbalanced supplied power, leading to unbalanced grid current. To solve this issue, a Fuzzy logic control scheme with modulation compensation is also proposed. In this paper, fuzzy with PI controller is proposed to enhance the power quality by diminishing voltage and current error. The studied system is modeled and simulated in the MATLAB/Simulink environment and the results obtained are compared with conventional PI Controller.*

**Key Words:** Cascaded Multilevel Inverter, Distributed Maximum Power Point Tracking (MPPT), Fuzzy Logic Controller (FLC) & Photovoltaic (PV).

### **1. Introduction:**

To meet the future energy demand of electricity DGs are the viable option as because it can provide a 1) secure and diversified energy options, 2) increase the generation and transmission efficiency, 3) reduce the emissions of greenhouse gases, and 4) improve the power quality and system stability. In spite of the several advantages, the main technical challenge is the synchronization of the DGs with the utility grid according to the grid code requirements [1]. In most of the cases power electronics converter, especially current controlled PWM-VSI is used for the integration of the DGs with utility grid. Five inverter families can be defined, which are related to different configurations of the PV system: 1) central inverters; 2) string inverters; 3) multistring inverters; 4) ac-module inverters; and 5) cascaded inverters [2]–[7]. The configurations of PV systems are shown in Figure 1.

Cascaded inverters consist of several converters connected in series; thus, the high power and/or high voltage from the combination of the multiple modules would favor this topology in medium and large grid-connected PV systems [8]–[10]. There are two types of cascaded inverters. Fig. 1(e) shows a cascaded dc/dc converter connection of PV modules [11], [12]. Each PV module has its own dc/dc converter, and the modules with their associated converters are still connected in series to create a high dc voltage, which is provided to a simplified dc/ac inverter. This approach combines aspects of string inverters and ac-module inverters and offers the advantages of individual module

maximum power point (MPP) tracking (MPPT), but it is less costly and more efficient than ac-module inverters.

However, the converter performance is largely depending on the applied control strategy. Very extensive research work has been done besides current control techniques and is available in the literature. [2]. The common strategies of current controllers can be classified as ramp comparator, hysteresis controller, PWM controller, PI Controller and Fuzzy Logic Controller amongst which the PI controllers are widely used because of their inherent simplicity and fast dynamic response [3]. The main objectives of the control of grid connected PWM-VSI with Fuzzy + PI controller is to 1) ensure grid stability 2) active and reactive power control through voltage and frequency control 3) power quality improvement (i.e. harmonic elimination) etc. In this paper fuzzy with PI controller is proposed to enhance the power quality by diminishing voltage and current error. The studied system is modeled and simulated in the MATLAB/Simulink environment and the result obtained is compared with the conventional PI controller.

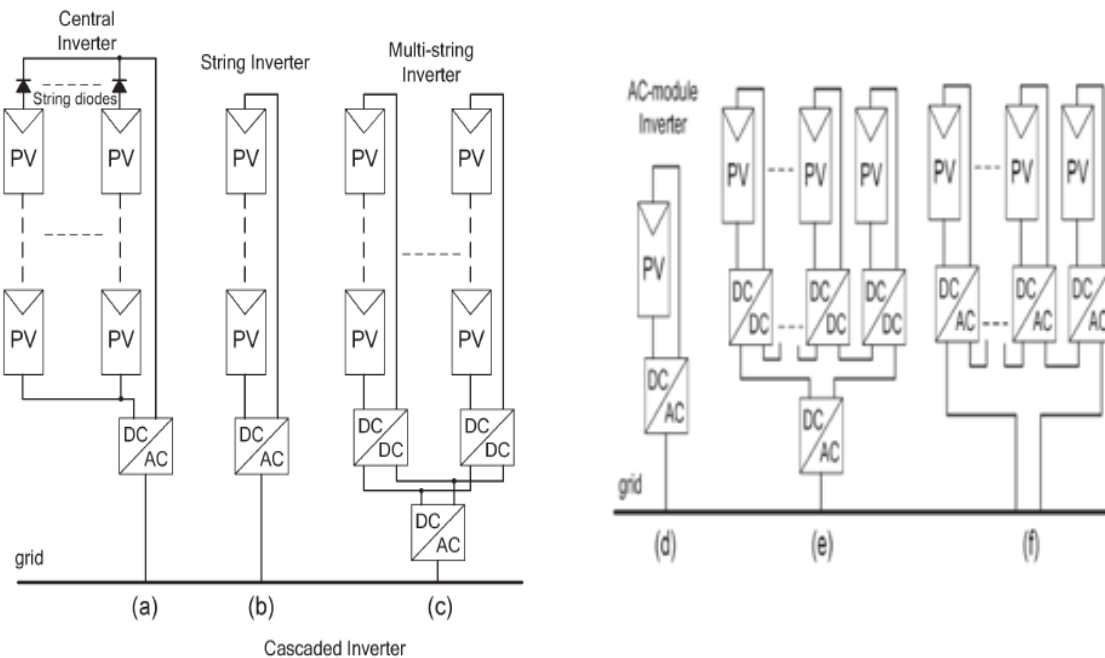

Figure 1: Configuration of PV systems (a) Central inverter, (b) String inverter, (c) Multi string inverter, (d) AC-module inverter, (e) Cascaded DC/DC converter, (f) Cascaded DC/AC inverter

## 2. System Description:

Modular cascaded H-bridge multilevel inverters for single and three-phase grid-connected PV systems are shown in Fig. 2. Each phase consists of  $n$  H-bridge converters connected in series, and the dc link of each H-bridge can be fed by a PV panel or a short string of PV panels. The cascaded multilevel inverter is connected to the grid through  $L$  filters, which are used to reduce the switching harmonics in the current. By different combinations of the four switches in each H-bridge module, three output voltage levels can be generated:  $-v_{dc}$ ,  $0$ , or  $+v_{dc}$ . A cascaded multilevel inverter with  $n$  input sources will provide  $2n + 1$  levels to synthesize the ac output waveform. This  $(2n + 1)$ -level voltage waveform enables the reduction of harmonics in the synthesized current, reducing the size of the needed output filters. Multilevel inverters also have other advantages such as reduced voltage stresses on the semiconductor switches and having higher efficiency when compared to other converter topologies [13].

### 3. Panel Mismatches:

PV mismatch is an important issue in the PV system. Due to the unequal received irradiance, different temperatures, and aging of the PV panels, the MPP of each PV module may be different. If each PV module is not controlled independently, the efficiency of the overall PV system will be decreased. To show the necessity of individual MPPT control, a five-level two-H-bridge single-phase inverter is simulated in MATLAB/SIMULINK. Each H-bridge has its own 185-W PV panel connected as an isolated dc source. The PV panel is modeled according to the specification of the commercial PV panel. Consider an operating condition that each panel has a different irradiation from the sun; panel 1 has irradiance  $S = 1000 \text{ W/m}^2$ , and panel 2 has  $S = 600 \text{ W/m}^2$ . If only panel 1 is tracked and its MPPT controller determines the average voltage of the two panels, the power extracted from panel 1 would be 133W, and the power from panel 2 would be 70W, as can be seen in Fig.3. Without individual MPPT control, the total power harvested from the PV system is 203 W.

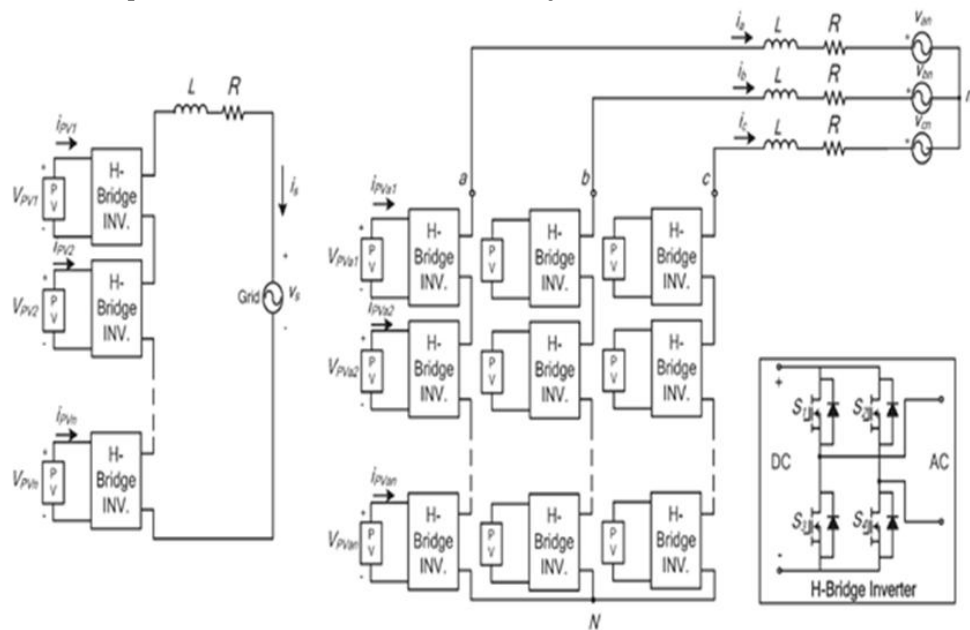

Figure 2: Topology of the modular cascaded H-bridge multilevel inverter for grid connected PV systems

However, Figure 4 shows the MPPs of the PV panels under the different irradiance. The maximum output power values will be 185 and 108.5 W when the  $S$  values are 1000 and 600  $\text{W/m}^2$ , respectively, which means that the total power harvested from the PV system would be 293.5 W if individual MPPT can be achieved. This higher value is about 1.45 times of the one before. Thus, individual MPPT control in each PV module is required to increase the efficiency of the PV system.

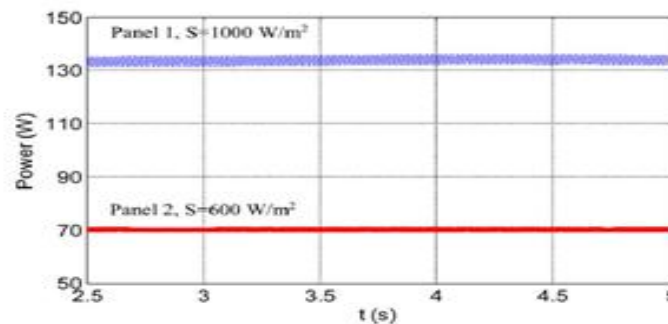

Figure 3: Power extracted from two PV panels

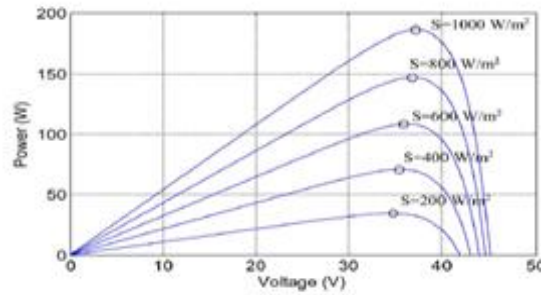

Figure 4: P-V characteristics under the different irradiance

**4. Control Scheme:**

**Distributed MPPT Control:**

In order to eliminate the adverse effect of the mismatches and increase the efficiency of the PV system, the PV modules need to operate at different voltages to improve the utilization per PV module. The separate dc links in the cascaded H-bridge multilevel inverter make independent voltage control possible. To realize individual MPPT control in each PV module, the control scheme proposed in [14] is updated for this application. The distributed MPPT control with Fuzzy logic controller of the three-phase cascaded H-bridge inverter is shown in Fig. 7. In each H-bridge module, an MPPT controller is added to generate the dc-link voltage reference. Each dc-link voltage is compared to the corresponding voltage reference, and the sum of all errors is controlled through a total Fuzzy logic controller that determines the current reference  $I_{dref}$ .

The structure of fuzzy logic controller is given below in fig 5.

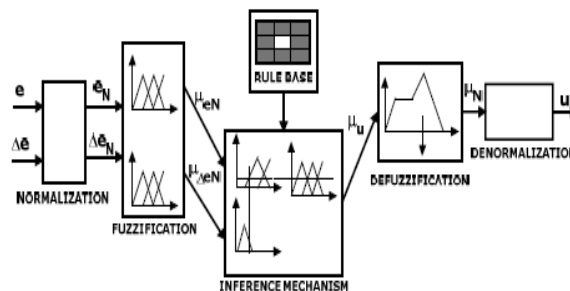

Figure 5: Structure of Fuzzy logic controller

Here the membership function is chosen as triangular as shown in fig 6. The input is taken as error ( $e$ ) and the change in error ( $\Delta e$ ). Total 49 rules are taken into account

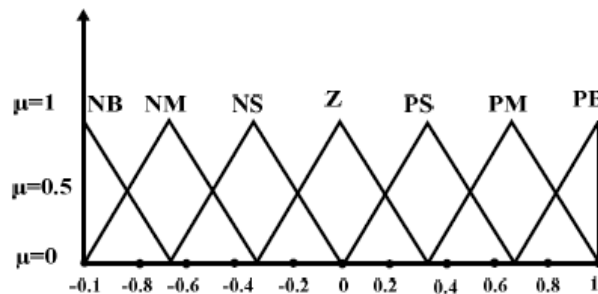

Figure 6: Membership function

For example If  $e$  is negative small (NS) and  $\Delta e$  is positive big (PB) Then output is positive medium (PM).

The reactive current reference  $I_{qref}$  can be set to zero, or if reactive power compensation is required,  $I_{qref}$  can also be given by a reactive current calculator. The synchronous reference frame phase-locked loop (PLL) has been used to find the phase

angle of the grid voltage. As the classic control scheme in three-phase systems, the grid currents in abc coordinates are converted to dq coordinates and regulated through proportional-integral (PI) controllers to generate the modulation index in the dq coordinates, which is then converted back to three phases.

The distributed MPPT control scheme for the single-phase system is nearly the same. The total voltage controller gives the magnitude of the active current reference, and a PLL provides the frequency and phase angle of the active current reference. The current loop then gives the modulation index.

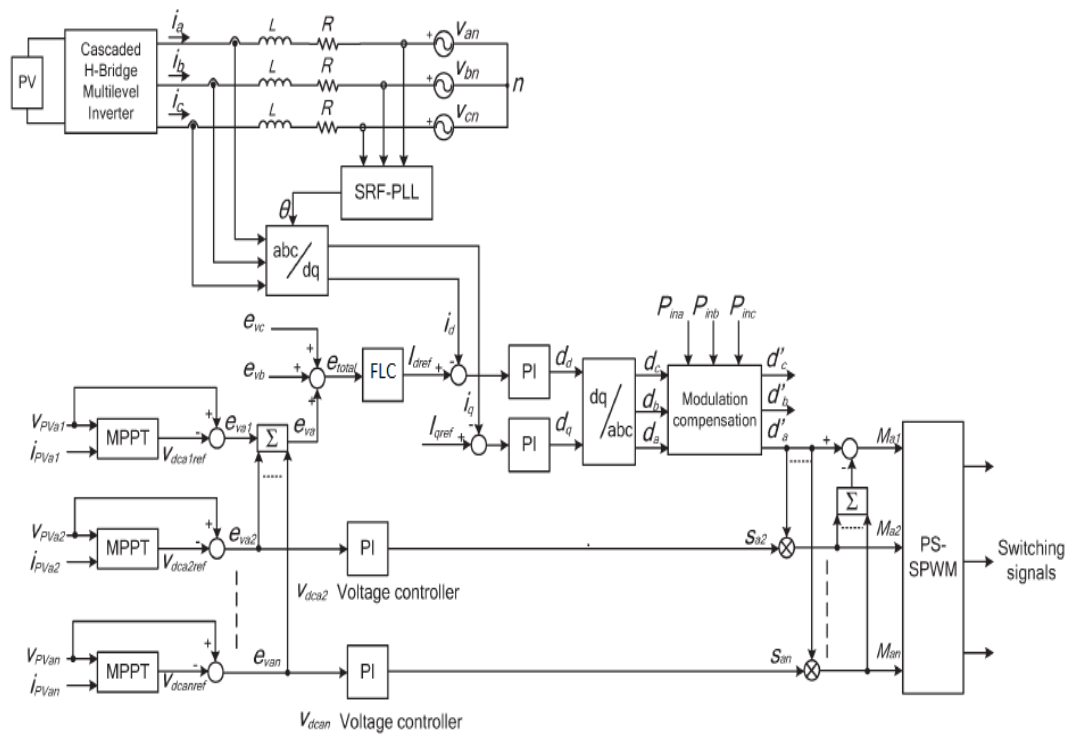

Figure 7: Control scheme for three-phase modular cascaded H-bridge multilevel PV inverter

Generally current regulated PWM voltage-source inverters (VSI) are used for synchronizing the utility grid with DG source in order to meet the following objectives: 1) To ensure grid stability 2) active and reactive power control through Fuzzy Logic and PI controller 3) power quality improvement (i.e. harmonic elimination) etc. For three-phase grid-connected applications, PV mismatches may introduce unbalanced supplied power, leading to unbalanced grid current. To solve this issue, a Fuzzy logic control scheme with modulation compensation is also proposed. In this project, a fuzzy with PI controller is used to enhance the power quality by diminishing voltage and current error.

### 5. Modulation Compensation:

As mentioned earlier, a PV mismatch may cause more problems to a three-phase modular cascaded H-bridge multi-level PV inverter. With the individual MPPT control in each H-bridge module, the input solar power of each phase would be different, which introduces unbalanced current to the grid. To solve the issue, a zero sequence voltage can be imposed upon the phase legs in order to affect the current flowing into each phase [25],[26]. If the updated inverter output phase voltage is proportional to the unbalanced power, the current will be balanced.

Thus, the modulation compensation block, as shown in below Fig.8, is added to the control system of three-phase modular cascaded multilevel PV inverters. The key is how to update the modulation index of each phase without increasing the complexity of the control system. First, the unbalanced power is weighted by ratio  $r_j$ , which is calculated as

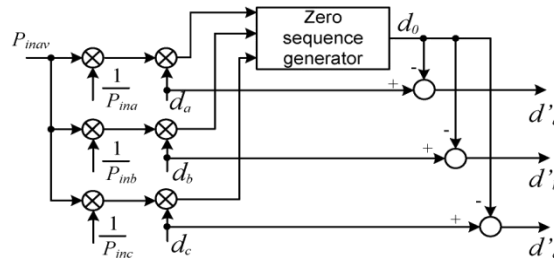

Figure 8: Modulation Compensation scheme

First, the unbalanced power is weighted by ratio  $r_j$ , which is calculated as

$$r_j = \frac{P_{inav}}{P_{inj}} \quad .. (1)$$

Where  $P_{inj}$  is the input power of phase  $j$  ( $j = a, b, c$ ), and  $P_{inav}$  is the average input power. Then, the injected zero sequence modulation index can be generated as

$$d_0 = \frac{1}{2} [\min(r_a \cdot d_a, r_b \cdot d_b, r_c \cdot d_c) + \max(r_a \cdot d_a, r_b \cdot d_b, r_c \cdot d_c)] \quad .. (2)$$

Where  $d_j$  is the modulation index of phase  $j$  ( $j = a, b, c$ ) and is determined by the current loop controller. The modulation index of each phase is updated by

$$d'_j = d_j - d_0 \quad .. (3)$$

Only simple calculations are needed in the scheme, which will not increase the complexity of the control system.

### 6. Simulation Results:

To verify the proposed control scheme, the three-phase grid connected PV inverter is simulated in two different conditions. First, all PV panels are operated under the same irradiance  $S = 1000 \text{ W/m}^2$  and temperature  $T = 25^\circ\text{C}$ . At  $t = 0.8\text{s}$ , the solar irradiance on the first and second panels of phase  $a$  decreases to  $600 \text{ W/m}^2$ , and that for the other panels stays the same. The dc-link voltages of phase  $a$  are shown. At the beginning, all PV panels are operated at an MPP voltage of  $36.4 \text{ V}$ . As the irradiance changes, the first and second dc-link voltages decrease and track the new MPP voltage of  $36\text{V}$ , while the third panel is still operated at  $36.4 \text{ V}$ . The PV current waveforms of phase  $a$  are shown in Fig. 13 and 14. After  $t = 0.8 \text{ s}$ , the currents of the first and second PV panels are much smaller due to the low irradiance, and the lower ripple of the dc-link voltage of phase  $a$  can be found in Fig. 9 for PI and Fig. 10 for Fuzzy controller. Simulation results are carried out to validate the proposed ideas. The dc-link voltages of phase  $b$  are shown in Fig.15 and 16(pi and fuzzy+pi). Figure 17 and 18 Power extracted from PV panels with distributed MPPT.

Figure 19 and 20 are the 3-phase inverter output voltage waveforms. Fig 21 and 22 are the 3-phase grid current waveforms with PI and PI+FUZZY Controller. Figure 23 and 24 shows the THD difference of phase  $a$  currents with PI and FUZZY+PI controller

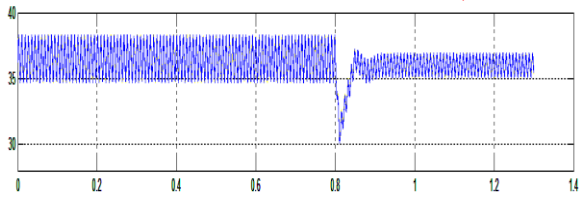

Figure 9: DC-link voltage of modules 1 and 2 of phase a with distributed MPPT (PI Controller)

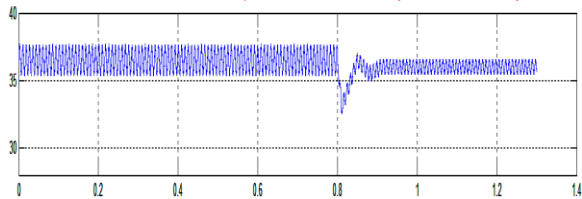

Figure 10: DC-link voltage of modules 1 and 2 of phase a with distributed MPPT (fuzzy PI controller)

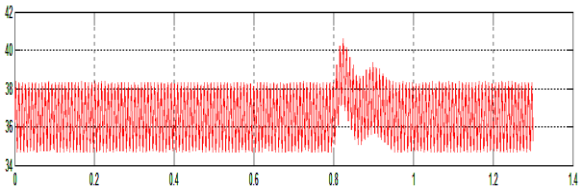

Figure 11: DC-link voltage of module 3 of phase a with distributed MPPT (PI Controller)

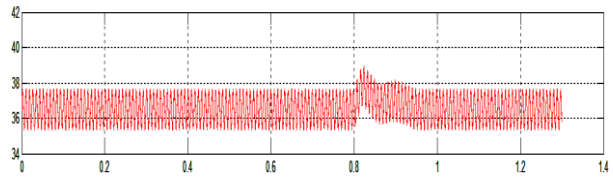

Figure 12: DC-link voltage of module 3 of phase a with distributed MPPT (fuzzy PI Controller)

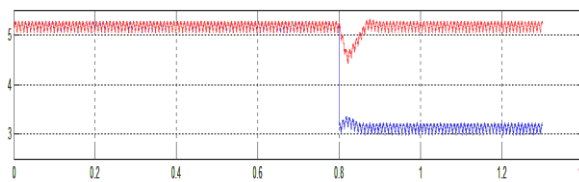

Figure 13: PV currents of phase a with distributed MPPT with PI Controller

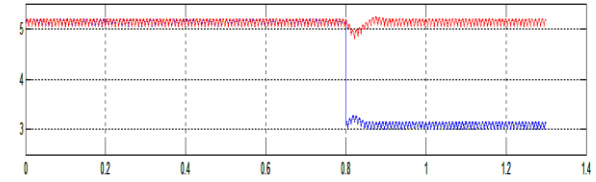

Figure 14: PV currents of phase a with distributed MPPT with FUZZY PI Controller

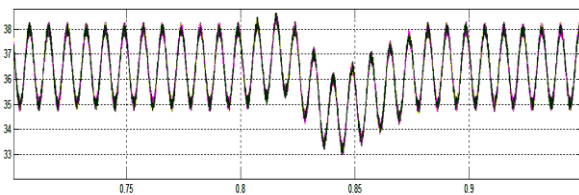

Figure 15: DC-link voltages of phase b with distributed MPPT with PI Controller

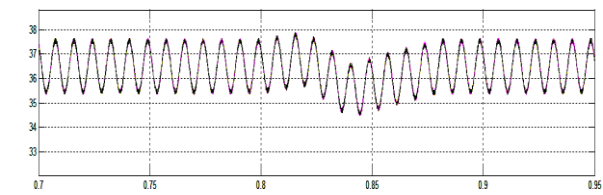

Figure 16: DC-link voltages of phase b with distributed MPPT with FUZZY PI Controller

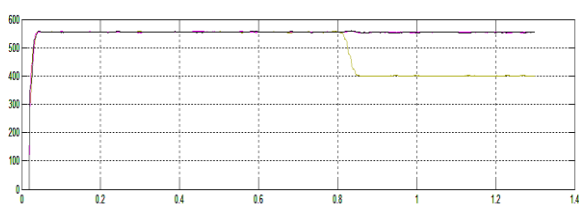

Figure 17: Power extracted from PV panels with distributed MPPT with PI Controller

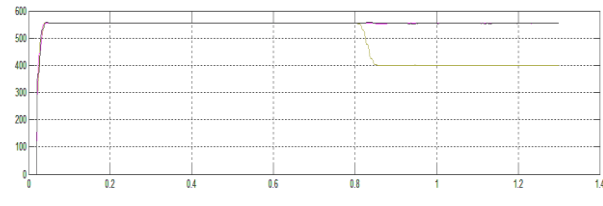

Figure 18: Power extracted from PV panels with distributed MPPT with Fuzzy PI Controller

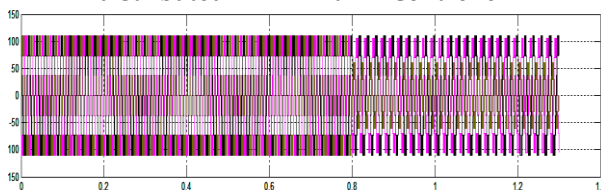

Figure 19: 3-phase inverter output voltage waveforms with modulation compensation with PI Controller

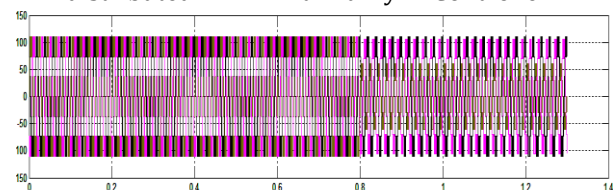

Figure 20: 3-phase inverter output voltage waveforms with modulation compensation with FUZZY PI Controller

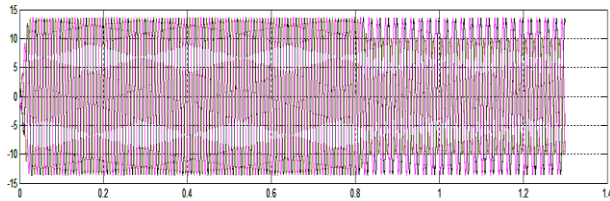

Fig 21. 3-phase grid current waveforms with modulation compensation with PI Controller

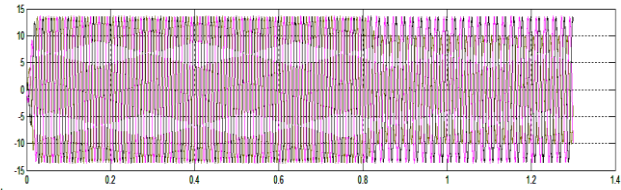

Fig 22. 3-phase grid current waveforms with modulation compensation with FUZZY PI Controller

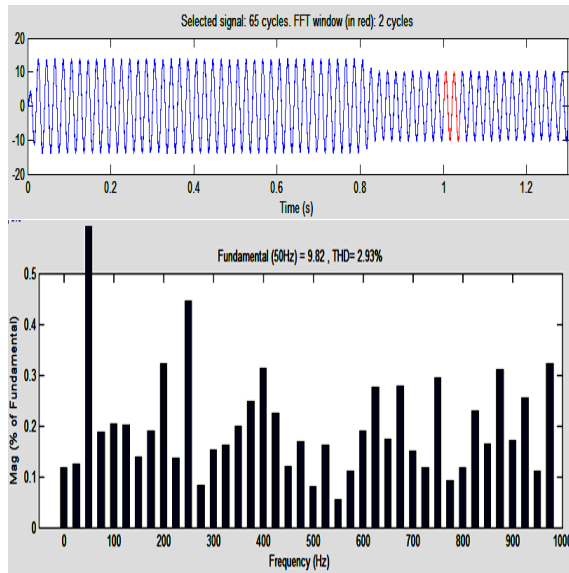

Fig 23. Harmonic Distortions of phase *a* with distributed MPPT (PI Controller) THD=2.93%

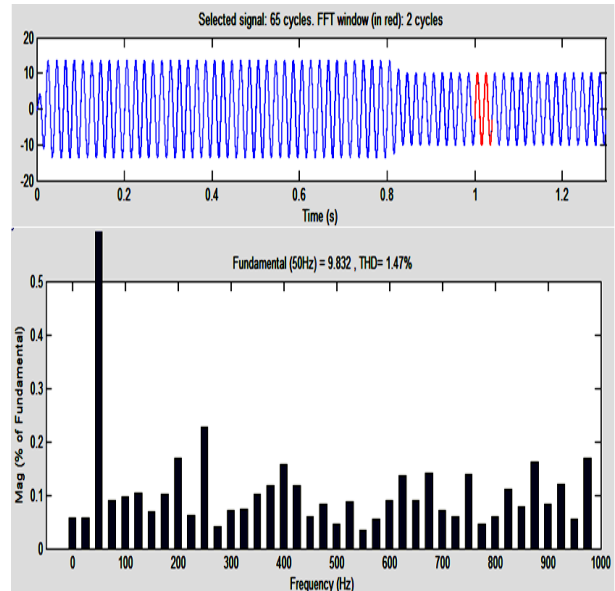

Fig 24. Harmonic Distortions of phase *a* with distributed MPPT (FUZZY PI Controller) THD=1.47%

## 7. Conclusion:

In this paper, a modular cascaded H-bridge multilevel inverter for grid-connected PV applications has been presented. The multilevel inverter topology will help to improve the utilization of connected PV modules if the voltages of the separate dc links are controlled independently. Thus, a distributed MPPT control scheme for three-phase PV systems has been applied to increase the overall efficiency of PV systems. For the three-phase grid-connected PV system, PV mismatches may introduce unbalanced supplied power, resulting in unbalanced injected grid current. A modulation compensation scheme, which will not increase the complexity of the control system or cause extra power loss, is added to balance the grid current. With the proposed Fuzzy logic control scheme, each PV module can be operated at its own MPP to maximize the solar energy extraction, and the three-phase grid current is balanced even with the unbalanced supplied solar power.

## 8. References:

1. J. M. Carrasco et al., "Power-electronic systems for the grid integration of renewable energy sources: A survey," *IEEE Trans. Ind. Electron.*, vol. 53, no. 4, pp. 1002–1016, Jun. 2006.
2. S. B. Kjaer, J. K. Pedersen, and F. Blaabjerg, "A review of single-phase grid connected inverters for photovoltaic modules," *IEEE Trans. Ind. Appl.*, vol. 41, no. 5, pp. 1292–1306, Sep./Oct. 2005.
3. M. Meinhardt and G. Cramer, "Past, present and future of grid connected photovoltaic- and hybrid power-systems," in *Proc. IEEE PES Summer Meet.*, 2000, vol. 2, pp. 1283–1288.

4. M. Calais, J. Myrzik, T. Spooner, and V. G. Agelidis, "Inverter for single phase grid connected photovoltaic systems — An overview," in Proc. IEEE PESC, 2002, vol. 2, pp. 1995–2000.
5. J. M. A. Myrzik and M. Calais, "String and module integrated inverters for single-phase grid connected photovoltaic systems—A review," in Proc. IEEE Bologna Power Tech Conf., 2003, vol. 2, pp. 1–8.
6. F. Schimpf and L. Norum, "Grid connected converters for photovoltaic, state of the art, ideas for improvement of transformerless inverters," in Proc. NORPIE, Espoo, Finland, Jun. 2008, pp. 1–6.
7. B. Liu, S. Duan, and T. Cai, "Photovoltaic DC-building-module-based BIPV system— Concept and design considerations," IEEE Trans. Power Electron., vol. 26, no. 5, pp. 1418–1429, May 2011.
8. L. M. Tolbert and F. Z. Peng, "Multilevel converters as a utility interface for renewable energy systems," in Proc. IEEE Power Eng. Soc. Summer Meet., Seattle, WA, USA, Jul. 2000, pp. 1271–1274.
9. H. Ertl, J. Kolar, and F. Zach, "A novel multicell DC–AC converter for applications in renewable energy systems," IEEE Trans. Ind. Electron., vol. 49, no. 5, pp. 1048–1057, Oct. 2002.
10. S. Daher, J. Schmid, and F. L. M. Antunes, "Multilevel inverter topologies for stand-alone PV systems," IEEE Trans. Ind. Electron., vol. 55, no. 7, pp. 2703–2712, Jul. 2008.
11. G. R. Walker and P. C. Sernia, "Cascaded DC–DC converter connection of photovoltaic modules," IEEE Trans. Power Electron., vol. 19, no. 4, pp. 1130–1139, Jul. 2004.
12. E. Roman, R. Alonso, P. Ibanez, S. Elorduizapatarietxe, and D. Goitia "Intelligent PV module for grid-connected PV systems," IEEE Trans. Ind. Electron., vol. 53, no. 4, pp. 1066–1073, Jun. 2006.
13. J. Rodriguez, J. S. Lai, and F. Z. Peng, "Multilevel inverters: A survey of topologies, controls, and applications," IEEE Trans. Ind. Electron., vol. 49, no. 4, pp. 724–738, Aug. 2002.
14. A. Dell'Aquila, M. Liserre, V. Monopoli, and P. Rotondo, "Overview of PI-based solutions for the control of DC buses of a single-phase H-bridge multilevel active rectifier," IEEE Trans. Ind. Appl., vol. 44, no. 3, pp. 857–866, May/June 2008.