



## **PHOTOVOLTAIC BASED FLEXIBLE MICROGRID SYSTEM USING FUZZY LOGIC**

**Gollangi Suresh\*, I. Prudhvi Kumar Raju\*\* & A. Hema Sundar Kumar\*\***

\* PG Scholar, Department of Electrical and Electronics Engineering, Pragati Engineering College, Surampalem, Andhra Pradesh

\*\* Assistant Professor, Department of Electrical and Electronics Engineering, Pragati Engineering College, Surampalem, Andhra Pradesh

### **Abstract:**

*This paper presents a flexible ac distribution system device for microgrid applications. The device aims to improve the power quality and reliability of the overall power distribution system that the microgrid is connected to. The control design employs a new model predictive control algorithm which allows faster computational time for large power systems by optimizing the steady-state and the transient control problems separately. In this paper Fuzzy logic controlling technique has been introduced to extract the harmonic spectra of the grid voltage and the load currents in the microgrid. The design concept is verified through different test case scenarios to demonstrate the capability of the proposed device and the Matlab/Simulink results are Presented.*

**Key Words:** Photovoltaic systems, PI controller, Fuzzy Logic controller, VSI & Microgrid

### **1. Introduction:**

The micro-grid concept has been gaining more notoriety each day. Some advantages of the micro-grids are the possibility to generate electric power with lower environmental impact and easier connection of these sources to the utility, including the power management capability among their elements. Regarding the connection methods of the distributed energy sources, energy storage devices, and load in a micro-grid, the dc bus is the simplest interconnection bus. This configuration results in high efficiency, high reliability, and no frequency or phase control requirements, when compared to the ac interconnection bus. Moreover, it has low distribution and transmission losses, low cost, the possibility to operate across long distances, and it does not use transformers, in turn leading to volume and cost reduction. Considering the local generation of distributed sources, residential micro-grids are being proposed as an interesting solution for increasing renewable energy production and system reliability for household appliances. One area of study for the connection of a micro grid to the distribution grid is the impact of power quality (PQ) problems on the overall power system performance frequency deviations in the grid voltage and harmonics in the grid voltage and load currents. To overcome the aforementioned PQ problems, several power conditioning equipments such as active filters [3],[4], uninterruptible power supplies [5], [6], dynamic voltage restorers [7], [8], and unified PQ conditioners [9] are usually employed by consumers to protect their loads and systems against PQ disturbances in the distribution network. However, these devices are usually installed at the consumer sides and the PQ problems that they are capable to handle are usually limited. This paper proposes a flexible ac distribution system device for the micro grid that is realized using a combination of series and shunt voltage source inverters (VSIs) and the controlling technique which we used is Fuzzy logic controller. The proposed device is installed at the point of common coupling (PCC) of the distribution grid that the micro grid and other electrical loads are connected to. The proposed source for the dc-link voltage of the flexible ac distribution system device consists of a photovoltaic (PV) array and a battery to store the excess energy generated by the PV array and to

provide power during sunless hours. The device is equipped with the capability to improve the PQ and reliability of the micro grid. Furthermore, during islanded operation of the micro grid, the device can provide real and reactive power to the micro grid.

The proposed controller depends on recently created demonstrate prescient control (MPC) calculation to track intermittent reference signals for quick examining direct time invariant (LTI) frameworks [15] that are liable to information limitations. This control system controls the info signs of the VSIs and decays the control issue into relentless state and transient sub issues which are streamlined independently. Thusly, the computational circumstances can be significantly decreased. This paper gives an exhaustive answer for the operation of the Flexible ac distribution system device for micro grid smaller scale lattice in light of a multi-input-multi-yield (i.e, Multi input-Multi output) state-space display.

The device will achieve the accompanying undertakings all the while:

- ✓ Compensating for harmonics in the grid voltage and load currents;
- ✓ Real and reactive power control for load sharing during peak periods and power factor correction at the grid side;
- ✓ Maintaining PQ despite slight voltage and frequency variations in the grid voltage; and
- ✓ Momentarily dispatching real and reactive power to the Micro grid when it becomes islanded.

## 2. System Description:

The configuration of the micro grid considered in this paper for implementation of the flexible ac distribution system device is shown in Fig. 1. The proposed micro grid consists of three radial feeders namely 1, 2 and 3, where feeders 1 and 3 are each connected to a distributed generation (DG) unit consisting of a micro-generator, a three-phase VSI, and a three-phase LC filter. Feeder 2, however, is connected to an electrical load. The flexible ac distribution system device is operated in two modes: 1) PQ compensation and 2) emergency operation. During grid-connected operation, the micro grid is connected to the distribution grid at the Point of common coupling. In this mode, the two DG units are controlled to provide local power and voltage support for loads 1–3 and hence reduce the burden of generation and delivery of power directly from the utility grid.

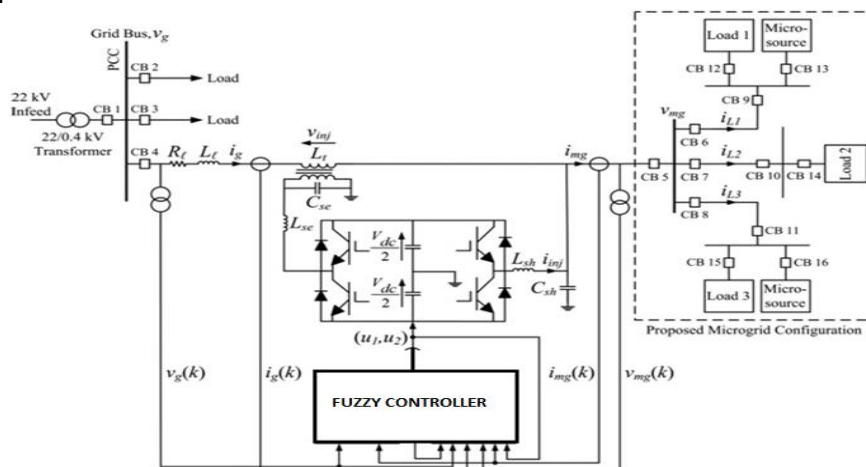

Figure 1: Proposed Block Diagram

The flexible ac distribution system device functions to compensate for any harmonics in the currents drawn by the nonlinear loads in the micro grid so that the

harmonics will not propagate to the rest of the electrical loads that are connected to the PCC. The device also functions to compensate for harmonics in the grid voltage that are caused by other nonlinear loads that are connected at the PCC. The energization of large loads and rapid changes in the load demand may also result in voltage and frequency variations in the grid voltage. Therefore, the device is also equipped with the capability to handle such voltage and frequency variations. When a fault occurs on the upstream network of the grid, the CBs operate to disconnect the micro grid from the grid. The DG units are now acts as the sole power sources left to regulate the loads. In the case when the generation capacity of the micro generators is unable to meet the total load demand, the flexible ac distribution system device transits to operate in the emergency mode and functions to momentarily provide for the shortage in real and reactive power. In Figure 2, the detailed configuration of the three-phase flexible ac distribution as shown in the figure.

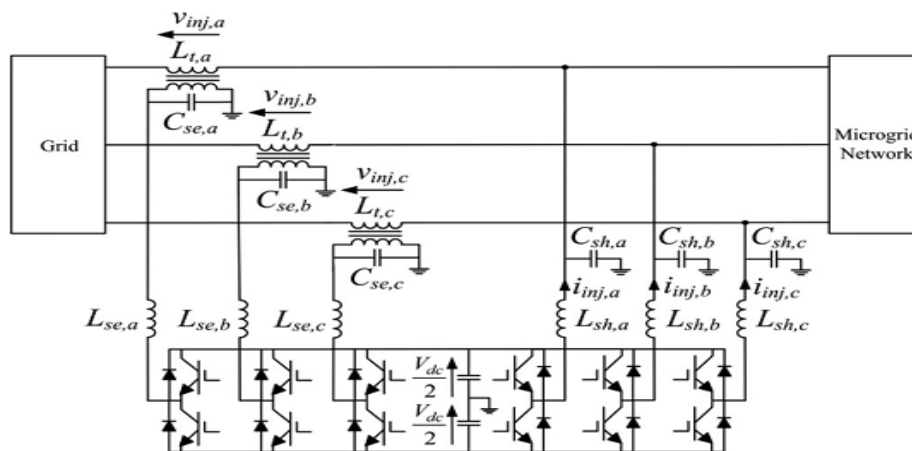

Figure 2: Configuration of three-phase flexible ac distribution system device

### 3. Flexible AC Distribution System Model:

The single-stage representation of Flexible AC distribution system device in Figure 3 [10]. The appropriation framework voltage at the PCC and the aggregate current drawn by the smaller scale network are displayed as  $v_g$  and  $i_{mg}$ , separately. With the expansion of force hardware gear being associated with the dispersion lattice and the miniaturized scale network, both  $v_g$  and  $i_{mg}$  could be mutilated because of the nearness of symphonious segments. Hence,  $v_g$  is demonstrated as a source comprising of its key  $v_f$  and consonant  $v_h$  that can be given by

$$V_g = V_f + V_h = v_f \sin(\omega t) + \sum_{h=3,5..}^N v_f (\sin h\omega t - \theta_h)$$

Where  $v_f$  is the fundamental component of  $v_g$  with its peak amplitude  $V_f$  and  $v_h$  is a combination of the harmonic components of  $v_g$  with its peak amplitude  $V_h$  and phase angle  $\theta_h$ . To compensate for the harmonics in  $v_g$ , the series VSI injects a voltage  $v_{inj}$  that is given by

$$V_{inj} = V_h - V_z - V_t$$

Where  $v_z$  is the voltage drop across the line impedance of  $R$  and  $L$ , and  $v_t$  is the voltage drop across the equivalent leakage reactance  $L_t$  of the series-connected transformer. Similarly,  $i_{mg}$  is also modeled as two components consisting of fundamental  $i_f$  and harmonic  $i_h$  with their peak amplitudes  $I_f$  and  $I_h$ , respectively and is represented by

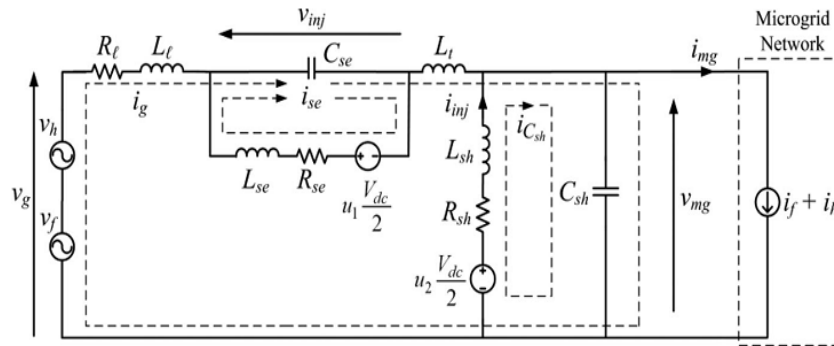

Figure 3: Single-phase representation of flexible ac distribution system device

$$i_{mg} = i_f + i_h = i_f \sin(\omega t - \phi_f) + \sum_h = 3.5 \dots I_h \sin(h\omega t - \phi_h) = i_{f,p} + i_{f,q} + i_h$$

where  $\phi_f$  and  $\phi_h$  are the respective phase angles of the fundamental and harmonic components of  $i_{mg}$ , and  $i_{f,p}$  and  $i_{f,q}$  are the instantaneous fundamental phase and quadrature components of  $i_{mg}$ . To achieve unity power factor at the grid side, compensate for the harmonics in the micro grid current and achieve load sharing concurrently, the shunt VSI injects a current  $I$  injected that is given by

$$\dot{i}_{inj} = (\dot{i}_{f,p} - \dot{i}_g) + \dot{i}_{f,q} + \dot{i}_h + \dot{i}_{Csh}$$

Where  $i_g$  is the grid current. The switched voltage across the series and shunt VSIs of the flexible ac distribution system device are represented by  $u_1$  ( $V_{ic}/2$ ) and  $u_2$  ( $V_{dc}/2$ ), respectively. To eliminate the high switching frequency components generated by the series and shunt VSIs, two second-order low-pass interfacing filters which are represented by  $L_{se}$ ,  $C_{se}$ ,  $L_{sh}$ , and  $C_{sh}$  are incorporated. The losses of the series and shunt VSIs are modeled as  $R_{se}$  and  $R_{sh}$ , respectively.

#### 4. Control Scheme:

This paper proposes a new MPC algorithm for the flexible ac distribution system device. The proposed algorithm is an extension of a recently developed MPC algorithm in [11], which is specifically designed for fast-sampling systems like the proposed flexible ac distribution system device to track periodic signals. This algorithm decomposes the MPC optimization into two sub problems: a steady-state sub problem and a transient sub problem, which are solved in parallel in different time scales, thus reducing the computational burdens. However, the MPC algorithm in [11] assumes that the periodic signals have a fixed and known frequency. In this paper, the algorithm is extended to allow an unknown frequency so that it will also be suitable for tracking frequency variations. It is known that any periodic signal with a finite number of harmonics can be written as the output of an autonomous finite-dimensional LTI state space model. In this paper Fuzzy logic controller has been employed in a control scheme to reduce the harmonic distortions somewhat accurately. Fuzzy logic is all about the relative importance of precision: use as Fuzzy Logic Toolbox software with MATLAB technical computing software as a tool for solving problems. Here we are implemented a 7X7 rule based structure to control MPC, the basic building block of Fuzzy is shown in figure 4.

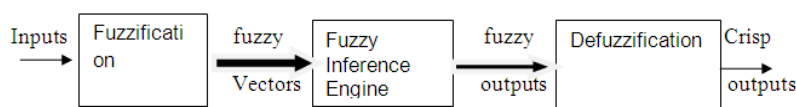

Figure 4: Block Diagram of Fuzzy Logic Controller

## 5. Grid Connected Photovoltaic Systems:

The photovoltaic (PV) control era frameworks are renewable vitality sources that normal to assume a promising part in satisfying the future power prerequisites. The PV frameworks mainly grouped into remain solitary, matrix associated or half and half frameworks. The lattice associated PV frameworks by and large shape the grid[1][2] current to take after a foreordained sinusoidal reference utilizing hysteresis-band current controller, which has the upsides of innate pinnacle current constraining and quick element execution. Fig.5 demonstrates the schematic outline of a matrix associated PV framework. It commonly comprises of two primary parts: the PV exhibit and the power molding unit (PCU). The PCU regularly incorporates:

- ✓ A Maximum Power Tracking (MPPT) circuit, which allows the maximum output power of the PV array.
- ✓ A Power Factor (PF) control unit, which tracks the phase of the utility voltage and provides to the inverter a current reference synchronized with the utility voltage.
- ✓ A converter, which can consist of a DC/DC converter to increase the voltage, a DC/AC inverter stage, an isolation transformer to ensure that the DC is not injected into the network, an output filter to restrict the harmonic currents into the network.

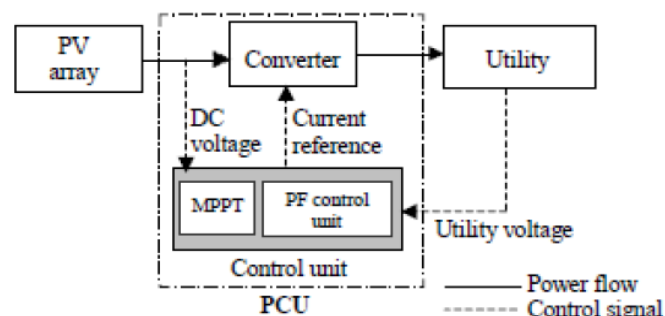

Figure 5: Schematic diagram of Grid connected PV system

The model of grid connected photovoltaic system to control active and reactive power injected in the grid is presented. The proposed multilevel power converter uses two single-phase voltage source inverters and a four wire voltage source inverter. The structural design of this new power converter allows a seven level shaped output voltage wave at the output of multilevel inverter. The MPPT algorithm, the synchronization of the inverter and the connection to the grid are discussed.

### A. Photovoltaic Array Modeling:

Various PV phones are joined in arrangement Furthermore parallel circuits once a board to acquiring helter skelter power, which is An PV module [12][13]. A PV show may be characterized concerning illustration bunch of a few modules electrically associated to series-parallel combinations on produce the needed current and voltage. The building square from claiming PV arrays may be those sun oriented cell, which will be fundamentally An p-n semiconductor intersection that specifically proselytes sunlight based radiation under dc current utilizing photovoltaic impact. The simplest equal circlet of a sun based cell is a current wellspring in parallel with An diode, demonstrated clinched alongside figure 6.

The arrangement imperviousness  $R_S$  speaks to the inside misfortunes because of those present stream. Shunt imperviousness  $R_{sh}$ , clinched alongside parallel with diode, this corresponds of the spillage current of the ground. Those single exponential mathematical statement which models a PV Mobile may be concentrated from the

material science of the PN intersection Furthermore may be broadly suitably as reverberating the conduct of the PV Mobile. Those grid combination for res provisions In light of photovoltaic frameworks may be getting to be today the A large portion paramount provision of PV systems, picking up interest through customary remain solitary frameworks. This pattern is, no doubt expanded due to those a significant number profits of utilizing res in conveyed (aka dispersed, installed alternately decentralized) era (DG) force frameworks.

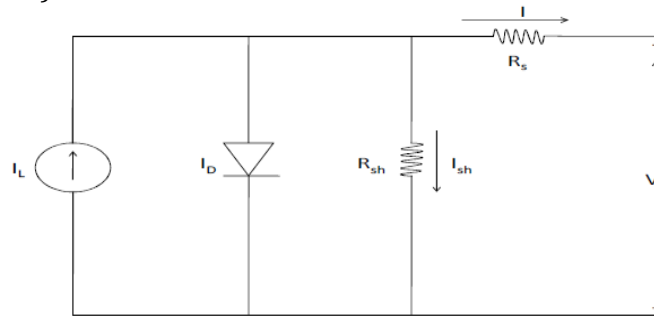

Figure 6: Circuit diagram of a Solar cell

**B. Proposed Hybrid Source for DC Link:**

The proposed source for the dc-link voltage of the flexible ac distribution system device consists of a PV array and a battery as shown in Fig. 7. The PV array and the battery are connected to the VSI of the device through a boost converter and a buck-boost converter, respectively, to facilitate charging and discharging operations for the battery and to regulate the dc-link voltage at the desired level. To maintain the dc-link at the reference voltage  $V_{dc}^*/2$ , a dual loop control scheme in [14], which consists of an outer voltage loop and an inner current loop for the bidirectional converter, is implemented to compensate for the variation in the output voltage  $V_{dc}/2$  of the dc/dc boost converter. In this section, the operation of the PV/battery system is briefly explained. When there is ample sunlight, the PV array is controlled by the dc/dc boost converter to operate in the MPPT [15] mode to deliver its maximum dc power  $P_{pv}$  at  $V_{dc}/2$ , which induces a voltage error  $(V_{dc}^*/2 - V_{dc}/2)$  at the dc-link. The error is passed to a PI controller, which produces a reference battery current  $i_{ab}$  for the inner current loop to operate the battery in either the charging mode for a positive error or discharging mode for a negative error.

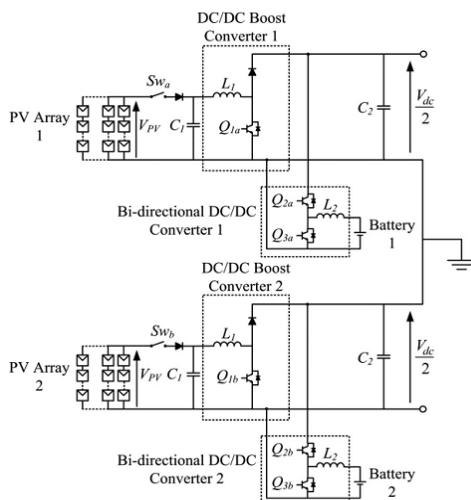

Figure 7: Proposed PV battery system

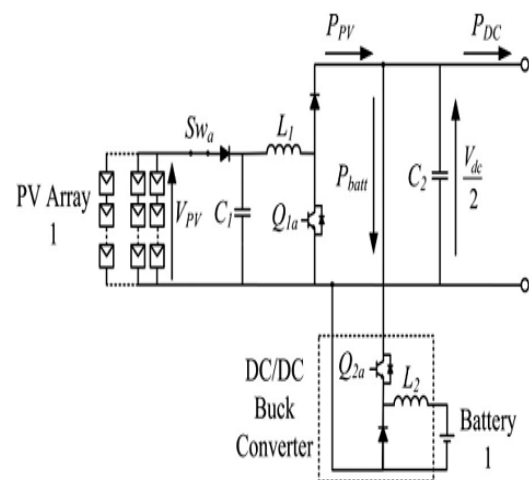

Figure 8: Circuit during charging operation

When the battery is in the charging mode, the bidirectional converter operates as a buck converter by turning switch  $Q3a$  OFF and applying the control signal from the controller to switch  $Q2a$  ON as shown in Fig. 6. Conversely, when the battery is in the discharging mode, the bidirectional converter operates as a boost converter by turning switch  $Q2a$  OFF and applying the control signal from the controller to switch  $Q3a$  ON as shown in Figure 7, Figure 8 and 9 illustrate the charging and discharging operations of Battery 1, so as to maintain the upper dc-link voltage at a desired value.

The same charging and discharging operations are applied to Battery 2 such that the dc-link voltages for both the upper and lower dc-link capacitors are maintained at  $V^*dc/2$ . When the PV array is subject to prolonged period of sunless hours and the state-of-charge of the battery falls below a preset limit, a self-charging technique from the grid can be incorporated into the design of the device.

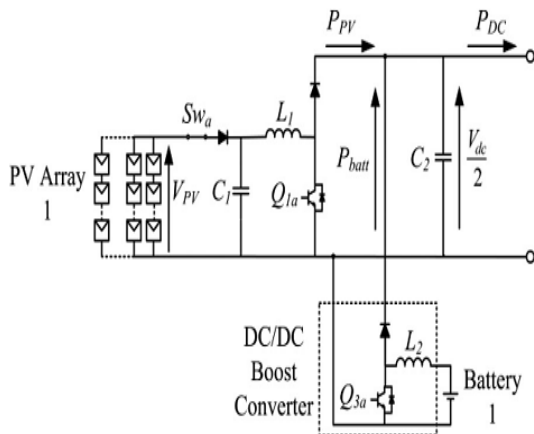

Figure 9: Circuit during discharging operation

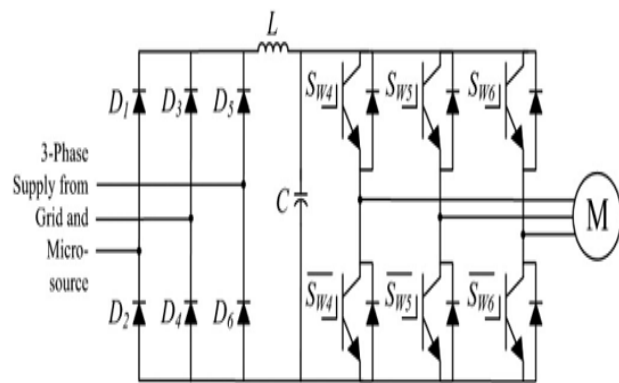

Figure 10: Configuration of a 3- phase ASD

## 6. Matlab Modeling and Simulation Results:

The proposed device is tested under different case scenarios using different controllers such as PI & Fuzzy logic using Simulink to evaluate its capability to improve the PQ and reliability of the distribution network that the microgrid is connected to. The Photovoltaic power system has been design and penetrates the PV power to power grid at near consumer distribution. Here simulation results are carried out for (1) Harmonic compensation and power factor correction during steady-state operation with load sharing (2) Grid current THD with PI & Fuzzy Logic controller.(3)General observations are made for Islanded operation. In the figure 17 it can be seen that dc voltage settles and stabilize at the reference value of 800v, and voltage ripple is maintained well within an acceptable range of about 1.25% tolerance. At  $t=0.16$  sec the increase in the generation demand from a device causes a small dip in the dc link voltage which is quickly restored back to the present value.

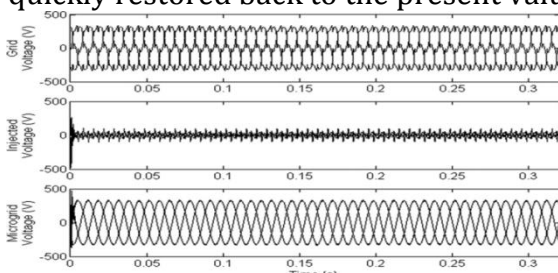

Figure 11: Grid voltage, Injected voltage, Microgrid voltage with PI Controller

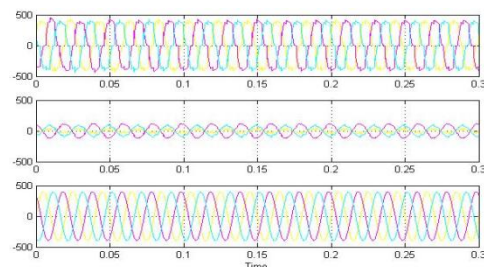

Figure 12: Grid voltage, Injected voltage, Microgrid voltage with Fuzzy Controller

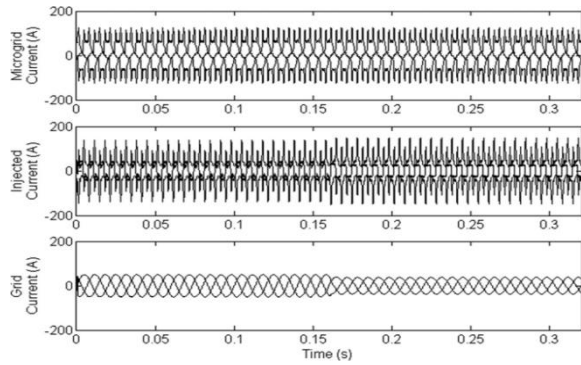

Figure 13: Microgrid current, Injected current & Grid current with PI Controller

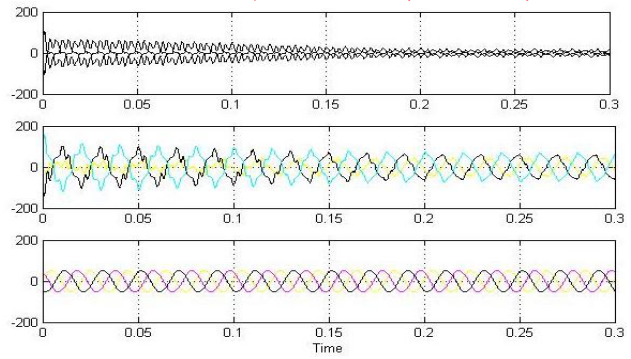

Figure 14: Microgrid current, Injected current & Grid current with Fuzzy Controller

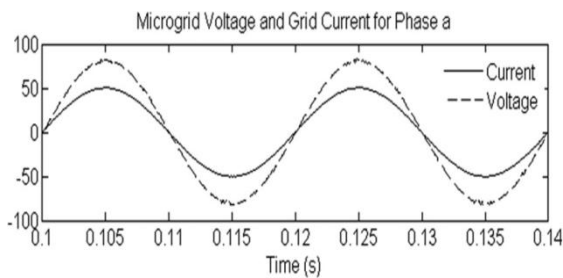

Figure 15: Waveforms of Microgrid voltage & Grid current with PI Controller

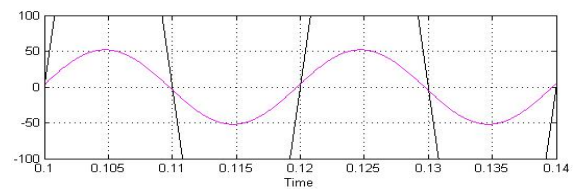

Figure 16: Waveforms of Microgrid voltage & Grid current with Fuzzy Controller

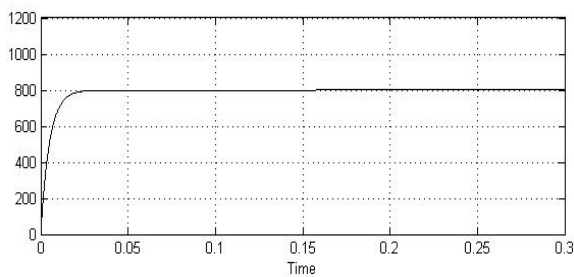

Figure 17: DC link voltage using Fuzzy Controller

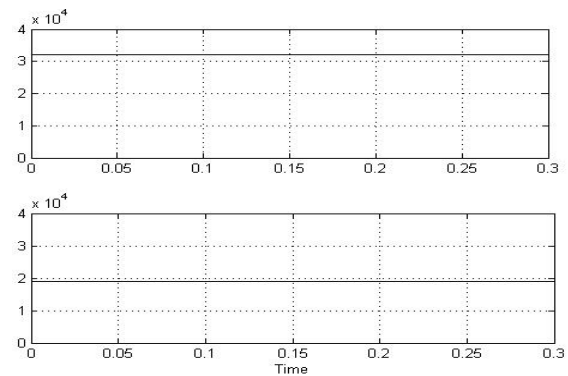

Figure 18: Top(Real) & Bottom(Reactive) power delivered by Microgrid with Fuzzy Controller

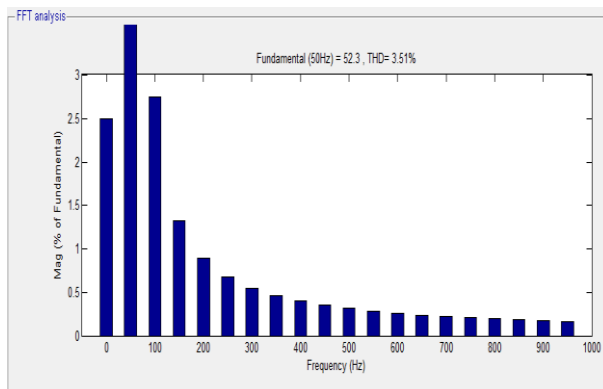

Figure 19: THD Comparison of Grid Current With PI Controller

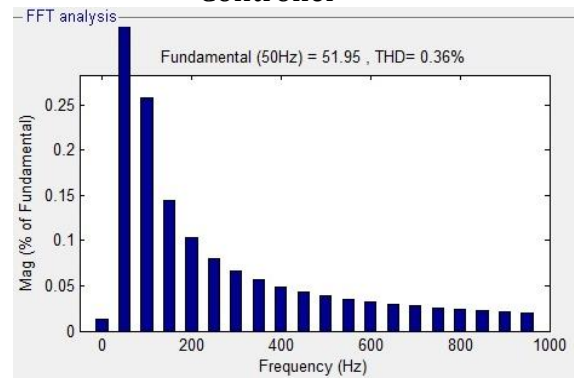

Figure 20: THD Comparison of Grid Current With Fuzzy Controller

### **Conclusion:**

The transportation of clean power has been always an important task for utilities. In this paper, a flexible ac Distribution system device for micro grid applications has been presented. The proposed solution integrates Fuzzy logic into the control design for and to extract the harmonic spectra of the grid currents. The device is installed at the PCC that the micro grid and other electrical networks are connected to and is designed to tackle a wide range of PQ issues. It also operates as a DG unit to perform load sharing when the cost of generation from the grid is high such that peak shaving is achieved and also during islanded operation of the micro grid.

The design concept has been implemented under several case scenarios as well as applied to induction drive loading condition using fuzzy logic control to check the performance of proposed concept and the results obtained verified that the device can handle a wide range of PQ issues, thus increasing the overall PQ and reliability of the micro grid. The simulation results obtained in this work and the current analysis serve as a fundamental step towards the design of control circuits for hardware implementation of the device in the future. In this paper Grid current THD has been improved from 3.51% to 0.36%

### **References:**

1. R. Lasseter, j. Eto, b. Schenkman, j. Stevens, H. Vollkommer, d. Klapp, e. Linton, H. Hurtado, Furthermore j. Roy, "Certs microgrid research center test bed, and advanced mobile loads," *IEEE Trans. Control Del.*, vol. 26, no. 1, pp. 325–332, jan. 2011.
2. An. Chambers, encountered with urban decay because of deindustrialization, innovation developed, government lodgin. Hamilton, Furthermore b. Schnoor, disseminated *Generation: An nontechnical aide*. Tulsa, OK, USA: Penn Well, 2001.
3. An. Luo, Z. Shuai, w. Zhu, and Z. J. Shen, "Combined framework for symphonious concealment Furthermore sensitive energy compensation," *IEEE Trans. Ind. Electron.*, vol. 56, no. 2, pp. 418–428, feb. 2009.
4. l. H. Tey, p. L. So, and Y. C's. Chu, "Improvement of energy nature utilizing versatile shunt dynamic filter," *IEEE Trans. Energy Del.*, vol. 20, no. 2, pp. 1558–1568, apr. Over 2,800 doctor look assignments led from April 1, 2009 to March 31, 2010.
5. An. Nasiri, Z. Nie, encountered with urban decay because of deindustrialization, engineering concocted, government lodgi. B. Bekiarov, What's more a. Emadi, "An on-line UPS framework for force component revision Also electric confinement utilizing BIFRED converter," *IEEE Trans. Ind. Electron.*, vol. 55, no. 2, pp. 722–730, feb. 2008..
6. M. Pascal, G. Garcer´ a, E. Figueres, and F. G. Esp´in, "Robust model following control of parallel UPS single-phase inverters," *IEEE Trans. Ind. Electron.*, vol. 55, no. 8, pp. 2870–2883, Aug. 2008.
7. A. Gosh, A. K. Jindal, and A. Joshi, "Design of a capacitor-supported dynamic voltage restorer (DVR) for unbalanced and distorted loads," *IEEE Trans. Power Del.*, vol. 19, no. 1, pp. 405–413, Jan. 2004.
8. D. M. Vilathagamuwa, H. M. Wijekoon, and S. S. Choi, "A novel technique to compensate voltage sags in multiline distribution system–The interline dynamic voltage restorer," *IEEE Trans. Ind. Electron.*, vol. 54, no. 4, pp. 2249–2261, Aug. 2007.

9. K. H. Kwan, Y. C. Chu, and P. L. So, "Model-based  $H_{\infty}$  control of a unified power quality conditioner," IEEE
10. An. Gosh What's more g. Ledwich, energy nature upgrade utilizing custom force units. Norwell, MA, USA: Kluwer, 2002, pp. 380–406.
11. Trans. Ind. Electron. , vol. 56, no. 7, pp. 2493–2502, Jul. 2009.
12. Y. C's. Chu What's more m. Z. Q. Chen, "Efficient model predictive calculations to following of occasional signals," j. Control Sci. Eng. , vol. 2012, pp. 1–13, 2012.
13. A. Pigazo and v. M. Moreno, Estimation from claiming electrical force amounts Eventually Tom's perusing method for Kalman sifting. Vienna, Austria: InTech, 2009, pp. 375– 396.
14. J. Mattingley, Y. Wang, Furthermore encountered with urban decay because of deindustrialization, engineering concocted, government lodgi. Boyd, "Receding Skyline control: programmed era for high-sounding solvers," IEEE control Syst. Mag. , vol. 31, no. 3, pp. 52–65, Jun. 2011.
15. X. Liu, p. Wang, Furthermore p. C. Loh, "A mixture AC/DC microgrid and its coordination control," IEEE Trans. Keen Grid, vol. 2, no. 2, pp. 278– 286, Jun. 2011.
16. C. Y. Teo, standards Furthermore plan about low Voltage frameworks. Singapore: byte force Publications, 1997.