



## **FACTS CONTROLLER INTEGRATED WITH ENERGY STORAGE DEVICES IN A POWER SYSTEM NETWORK**

**P. Poongodi\* & S. Hemasilviavinothini\*\***

Assistant Professor, Department of Electrical and Electronics Engineering, Nandha College of Technology, Erode, Tamilnadu

### **Abstract:**

*The voltage at the Point of Common Coupling (PCC) in a weak network is very sensitive to load changes. A sudden change in active load will cause both a phase jump and a magnitude fluctuation in the bus voltage, whereas reactive load changes mainly affect the voltage magnitude. With the addition of energy storage to a static synchronous compensator (STATCOM), it is possible to compensate for the active power change as well as providing reactive power support. A STATCOM can be employed to maintain the bus voltage level with the integration of energy storage to the STATCOM. This paper studies the control strategy for a STATCOM with energy storage for compensation of a cyclic load. Simulation studies are carried out in the Matlab/Simulink environment to examine the performance of the load with and without the STATCOM.*

**Key Words:** Reactive Power Compensation, Voltage Control, Point of Common Coupling (PCC), STATCOM & Energy Storage.

### **1. Introduction:**

Static synchronous Compensators (STATCOM) are widely used in power systems to provide voltage support by supplying reactive power. Integration of energy storage into the converter dc side makes it possible for a STATCOM to provide also active power support to the network. Investigations have shown enhanced performance, regarding power oscillation damping [1] [2] and voltage sag mitigation [3] [4], by the integration of energy storage into Voltage Source Converters (VSC). Studies have also shown that active power compensation can mitigate voltage changes related to phase jumps in a weak transmission system [5].

A particle accelerator is a typical cyclic load consuming pulsating reactive and active power with varying power factor. Fast magnetization and demagnetization of the main magnets require short rise and fall times of the power during each power cycle. The pulsating load power will create large fluctuations in the bus voltage at the connection point if there is no external voltage support device connected. In order to mitigate the voltage fluctuation, fast reactive power compensation is required. A Static Var Compensator (SVC) can serve this purpose [6]. The reactive power can be almost fully compensated by the SVC, whereas the pulsating active power will be supplied by the network.

This work investigates the possible use of a STATCOM with energy storage to improve the power quality at the Point of Common Coupling (PCC) where the cyclic load is connected. A control strategy for STATCOM integrated with energy storage device is proposed. Simulations have been performed with the power system simulation software MATLAB. The investigation shows that the phase jump and magnitude fluctuation in the PCC voltage can be reduced significantly by compensation of both the active and the reactive power.

A similar study has been carried out by Dragon Jovcic and Karsten Kahel [7]. A different control strategy is, however, proposed for compensation of particle accelerator load. In that study, the measured load power is taken as a feed-forward for ac voltage control, which in turn gives the dq component of the converter reference

voltage. Meanwhile, the load active power is controlled in an outer loop, delivering the reference dc voltage for the inner dc voltage control loop, which gives the quadrature component of the converter reference voltage. Although different control approaches are utilized in these two studies, the results are in good agreement.

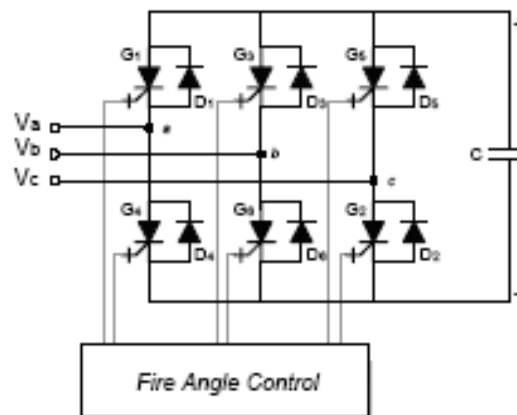
**2. Load Model:**

The cyclic load simulated in MATLAB is a model of a particle accelerator main magnet supplied from 48 pulses VSC. The first load is initially synchronised with the grid. The second load is switched on after 0.5 sec. The accelerator consumes cyclic active and reactive power. Fast magnetization of the main magnet requires a short rise time of the load current. When the acceleration is finished, the main magnet should be demagnetized quickly, requiring a short fall time of the current.

In the control system of the cyclic load implemented in MATLAB the outer loop controls the load current and gives the references of the thyristor converter output dc voltage. The inner load voltage control loop controls the converter output voltage and delivers the command of the converter firing angle  $\alpha$ .

**3. Voltage Source Inverter:**

The voltage source inverter is a DC to AC switching power converter using Gate Turn-off (GTO) thyristors in appropriate circuit configurations in order to generate a balanced set of three sinusoidal voltages at the fundamental frequency [8]. A phase control scheme involving multi-connected, elementary inverters in a suitable multi-pulse arrangement is used because no other control technique is currently acceptable for high power transmission system applications.



**Figure1. Basic Three-Phase, Three Level Voltage Source Inverter**

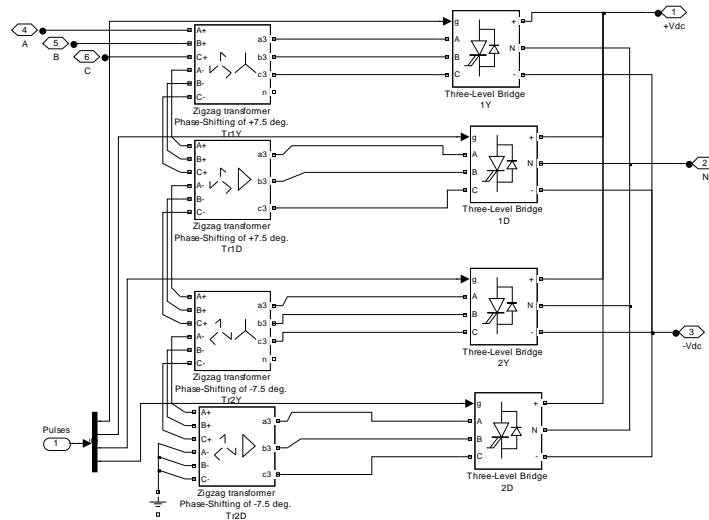
The VSI structure proposed is considerably different from conventional FACTS devices. In this case, the inverter is designed to make use of a three-level pole structure instead of a standard two-level, six-pulse inverter structure [6], [7]. A basic three-phase, three-level voltage source inverter is shown in Figure 1.

The inverter is referred to as three-level because of the DC voltage levels:  $-V_d/2$ , and  $+V_d/2$ . The addition of a level compared to the conventional structure is obtained by splitting each valve into two series-connected valves and connecting a clamping diode to the midpoint  $N$  of the DC capacitors, Thus, the three-level pole offers the additional flexibility of a level in the output voltage  $V_{inv}$ , which can be controlled in duration through conduction angle  $\beta$ , either to vary the fundamental output voltage of the inverter or to assist in the output waveform construction. The duration of level, through

angle  $\beta$ , is related to the duration of levels  $-V_d/2$  or  $+V_d/2$ , through conduction angle  $\sigma$  as

$$\sigma = 180 - 2\beta \tag{1}$$

As in the case of two-level inverters, multi-level inverters can also be combined so as to obtain the required multi-pulse inverter structure. Hence, by using zigzag phase-shifting transformers and the appropriate phase of switching of valves, the principle of harmonic neutralization can be applied [9].



**Figure2. 48-Pulse Voltage Source Inverter**

This allows reducing the harmonic level of the output voltage waveform, Figure 2, shows the scheme of four basic three-level inverters, producing an equivalent 48-pulse VSI.

The average DC bus voltage,  $V_d$  is related to the RMS fundamental output voltage of the VSI,  $V_{inv}$  by:

$$V_{inv} = k_a V_d / 2 \sin \sigma / 2 \tag{2}$$

Where:  $a$  is the total voltage ratio of the zig-zag phase-shifting transformers, given by the following equation:

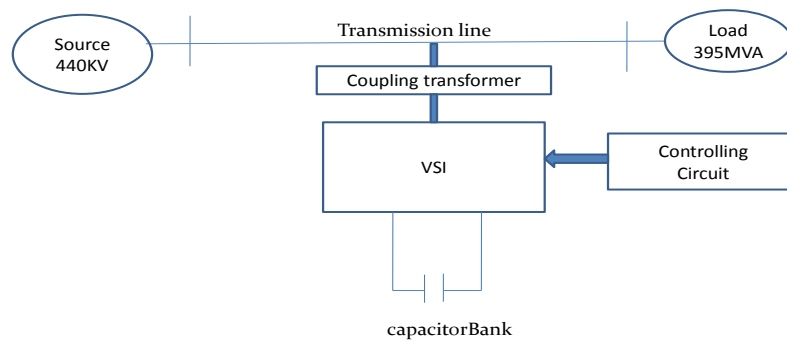
$$a = 4 - n_2 / n_1 \tag{3}$$

and  $k$  is a constant associated with the pulse-number of the VSI, which in the case of the 48-pulse inverter is:

$$k = 2\sqrt{3} / \pi \tag{4}$$

**4. Modelling and Control of STATCOM:**

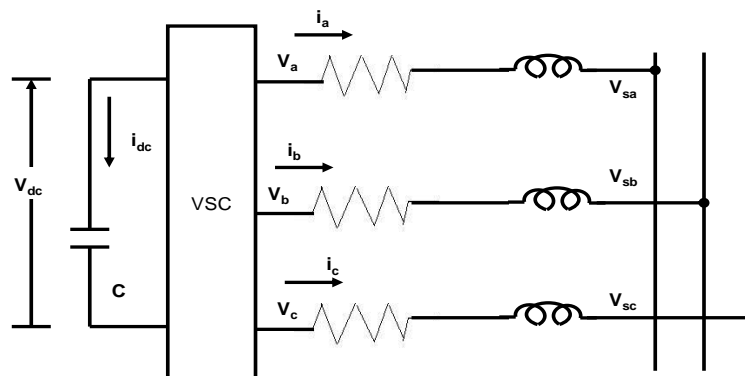
The STATCOM is a shunt FACTS device. It consists of a VSC that is connected in shunt to a bus through a coupling transformer, as shown in Figure 3. A STATCOM is a shunt connected device which injects reactive current into the system. This leading or lagging current, which can be controlled independently of the ac system voltage, is supplied through a power electronics-based variable voltage source. The STATCOM does not employ capacitor or reactor banks to produce reactive power. In the STATCOM, the capacitor is used to maintain a constant DC voltage in order to allow the operation of the voltage source converter. The objective of the STATCOM is to provide fast and smooth voltage regulation at the PCC [10].



**Figure 3 Block diagram of the test system**

In this paper, the VSC is modelled as a 48-pulse VSC with a dc-link capacitor. The three inductances are used as low-pass filters to eliminate the high frequency harmonics in the VSC ac-side currents.

Figure 4 shows the simplified equivalent circuit of the STATCOM. It contains a dc-link capacitor, a VSC, and series inductances in the three lines connecting to the system bus. These inductances account for the leakage inductances of the power transformer, as well as the inductances used for filtering the STATCOM ac-side currents. The circuit also includes resistance in shunt with the capacitor to represent the switching losses in the inverter, and resistance in series with the ac lines to represent the VSC and transformer conduction losses.



**Figure 4. Equivalent circuit**

Assuming balanced conditions, the ac-side circuit equations in Figure. 4 can be written in a synchronously rotating reference frame using the d-q transformation. Under balanced conditions, using dq transformation, the equations can be written in a synchronously rotating reference frame as:

$$\frac{di_d}{dt} = \frac{-R}{L}i_d + \omega_s i_q + \frac{1}{L}V_d - \frac{1}{L}V_{sd} \quad (5)$$

$$\frac{di_q}{dt} = \frac{-R}{L}i_q + \omega_s i_d + \frac{1}{L}V_q - \frac{1}{L}V_{sq} \quad (6)$$

Where  $(i_d, i_q)$ ,  $(v_d, v_q)$ , and  $(v_{sd}, v_{sq})$  are the dq components of  $(i_a, i_b, i_c)$ ,  $(v_a, v_b, v_c)$ , and  $(v_{sa}, v_{sb}, v_{sc})$ , respectively. Neglecting the harmonics due to switching and the losses in the VSC and the transformer, the power balance between the ac and dc sides of the VSC is given by

$$\frac{3}{2}(v_{sd}i_d + v_{sq}i_{sq}) = v_{dc}i_{dc} \tag{7}$$

With correct alignment of the reference frame, the  $v_{sq}$  term is zero, and hence, the following equation can be written to relate the dc-link voltage to the d-axis current  $i_d$  and voltage  $v_{sd}$ :

$$\frac{dv_{dc}}{dt} = \frac{3v_{sd}i_d}{2Cv_{dc}} \tag{8}$$

The dynamics of the VSC can be described by a set of first order Ordinary Differential Equations (ODEs). Since equation 8 is a nonlinear equation of the dc-link voltage, this set of ODEs represent a nonlinear model to be controlled. In terms of the instantaneous variables in, the reactive power balance at the PCC (15 kV bus) is given by

$$P = 3/2 (V_d i_d + V_q i_q) \tag{9}$$

$$Q = 3/2 (V_q i_d - V_d i_q) \tag{10}$$

Aligning the d-axis of the reference frame along the grid voltage position,  $V_q = 0$

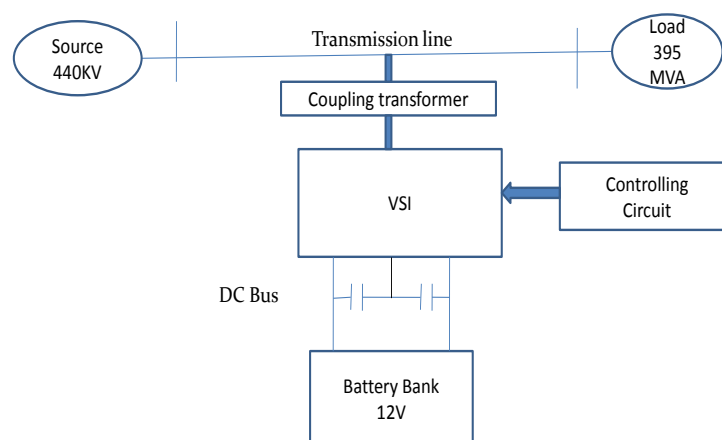
$$P = 3/2 V_d i_d \tag{11}$$

$$Q = -3/2 V_q i_d \tag{12}$$

From the above equations, it can be seen that Q can be controlled through  $i_q$  and  $V_{dc}$  can be controlled through  $i_d$ .

**5. The DC-DC Chopper and SMES Coil:**

A Superconducting Magnetic Energy Storage coil is connected to a voltage source inverter through a dc-dc chopper. It controls dc current and voltage levels by converting the inverter dc output voltage to the adjustable voltage required across the SMES coil terminal. The purpose of having inter-phase inductors is to allow balanced current sharing for each chopper phase.



**Figure 5: STATCOM Integrated with Battery**

A two-quadrant n-phase DC-DC converter is proposed as this interface. In such device, n is related to the maximum current driven by the SMES coil. This converter which allows decreasing the ratings of the overall power devices by regulating the current flowing from the SMES coil to the inverter of the FACTS controller. In addition it allows varying the amplitude of the output voltage of the VSI.

The two-quadrant, multi-phase chopper is composed of many shunt-connected diode-thyristor legs, which allow driving the high current ratings stored in the SMES coil. A smooth transition from charge to discharge mode and vice-versa is ensured by the two-quadrant configuration.

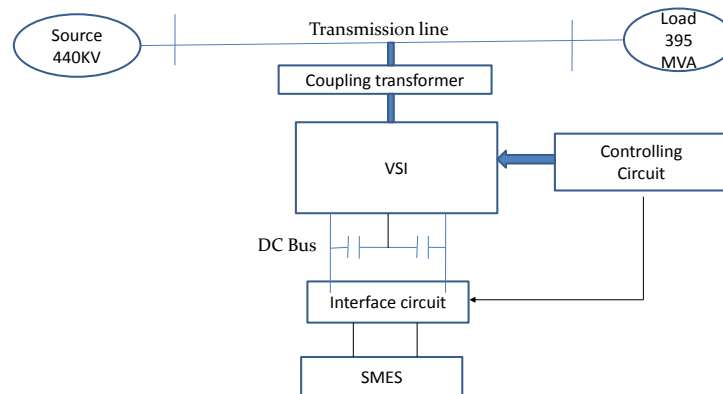
The DC-DC chopper has three modes of operation, namely the charge, the discharge and the stand-by mode. In the charge mode, the chopper works as a step-down converter. The relationship between the voltage of the SMES coil and the DC bus

$$V_l = DV_d \quad (13)$$

Once completed the charging of the SMES coil, the operating mode of the converter is changed to the stand-by mode.

Finally in the discharge mode the chopper operates as a step-up converter jointly with the DC bus capacitors. The relationship between the coil voltage and the DC bus voltage is given by

$$-V_l = (1-D)V_d \quad (14)$$



**Figure 6: STATCOM Integrated with SMES coil**

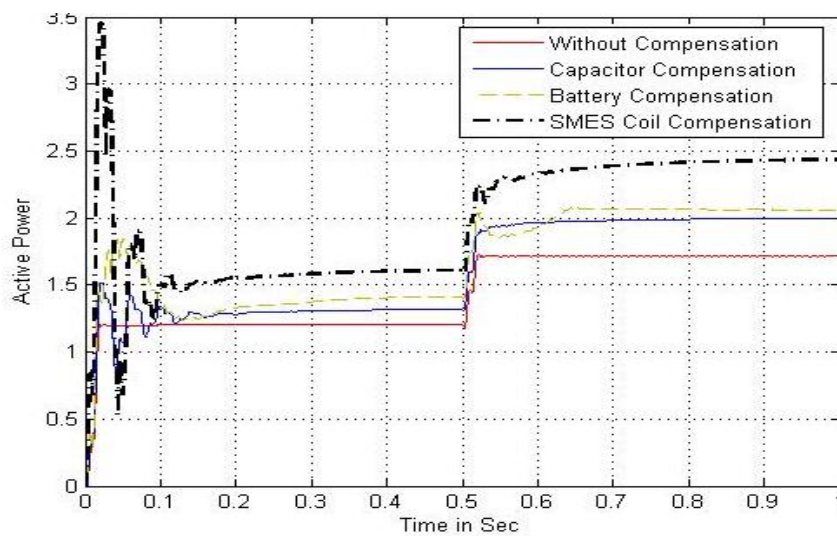
## 6. Experimental Results:

When a load is connected to a grid without STATCOM, the power flow between the grid and load should be controlled and the voltage at certain level should be kept at a reasonable and relatively constant value to ensure a successful operation. The simulations have been performed in MATLAB to verify the proposed compensation strategy circuit. Sudden change in load will cause bus voltage magnitude deviations as well as phase jumps.

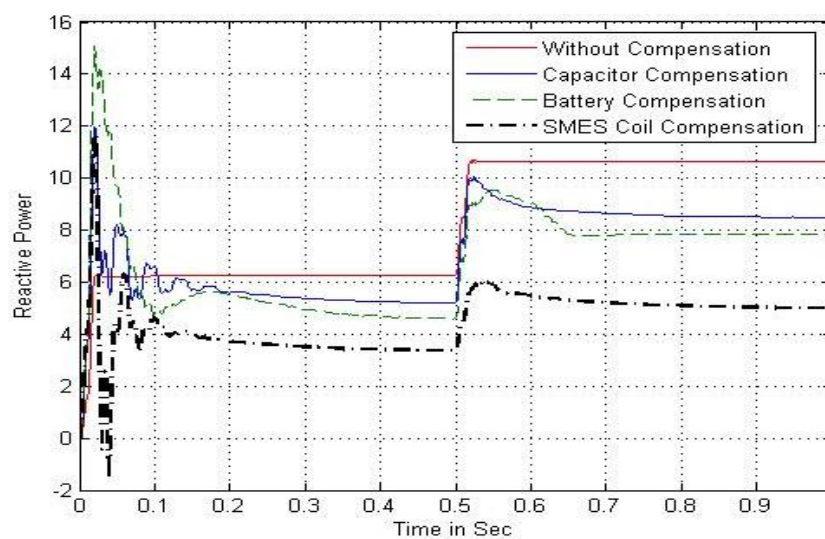
To overcome this STATCOM integrated with energy storage device is implemented. The simulation configuration is shown in Figure 6. A weak network with fluctuant active load is simulated and an inductive load is connected and disconnected occasionally. If any fault occurs the voltage and active power will be minimized. The reliability and stability is very low for this method. The load total capacity is 395MVA.

For the general function of the STATCOM, providing reactive power to the network to maintain the bus voltage level, the converter can be controlled only by the bus flux controller. The PI controller takes action only when bus flux deviations have been detected; and its control speed is limited. On the other hand, the load reactive power keeps changing during each load cycle. Hence, even though the bus voltage deviation can be quite long, in order to obtain a faster voltage control, the pulsating reactive power should be compensated directly. The measured reactive power of the load can be taken as a feed-forward to command the required current and thus reactive power from the converter.

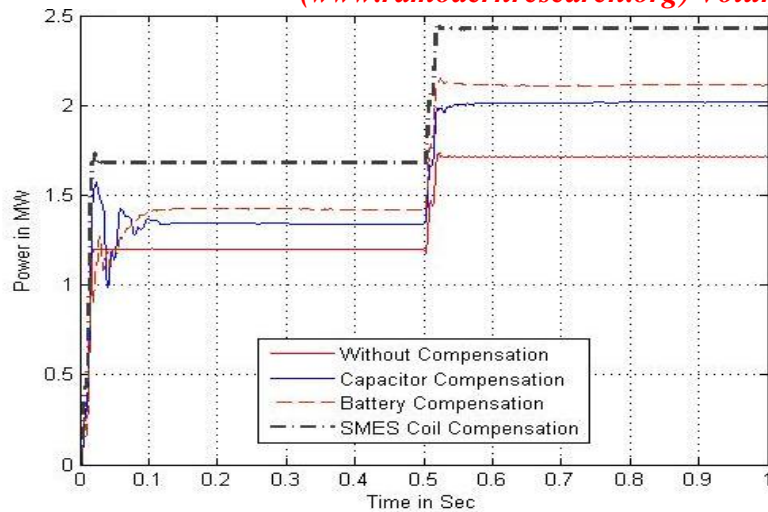
STATCOM circuit integrated with battery Figure (5) and SMES coil Figure(6) is simulated and a comparison is made with the simulated results STATCOM integrated with energy storage device is connected at Sending end, Midpoint and Receiving end and the simulated results are shown in Figure 7 to 18. The system data for the voltage, active power, reactive power at sending end midpoint, receiving end are shown in table 1,2,3,4.



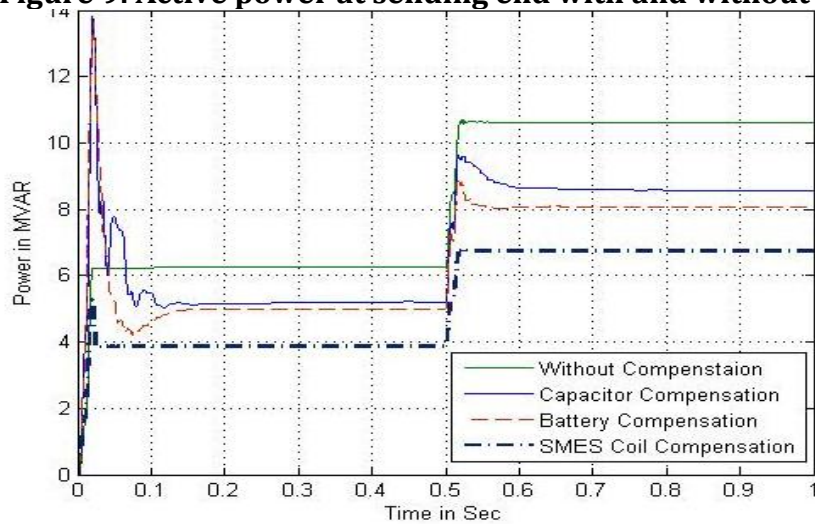
**Figure 7: Active power at mid point with and without STATCOM**



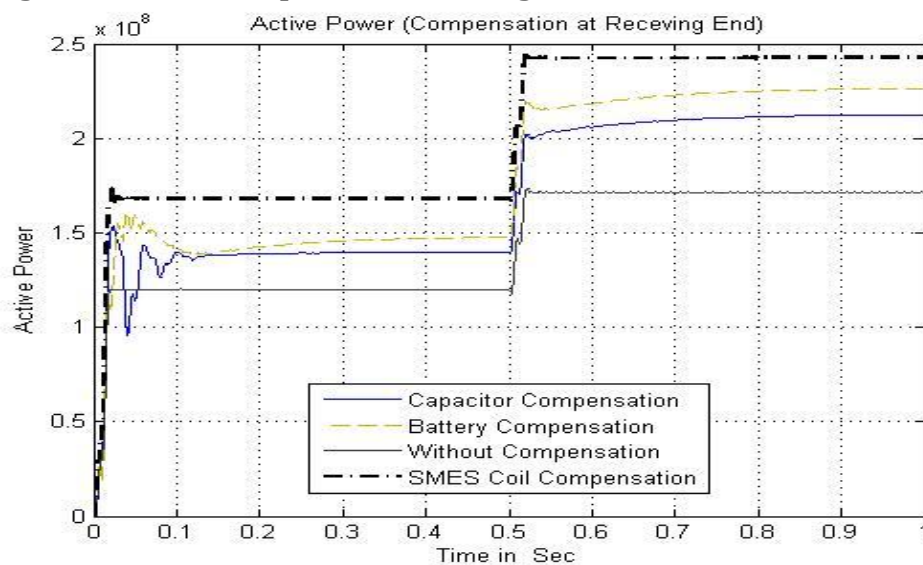
**Figure 8: Reactive power at mid point with and without STATCOM**



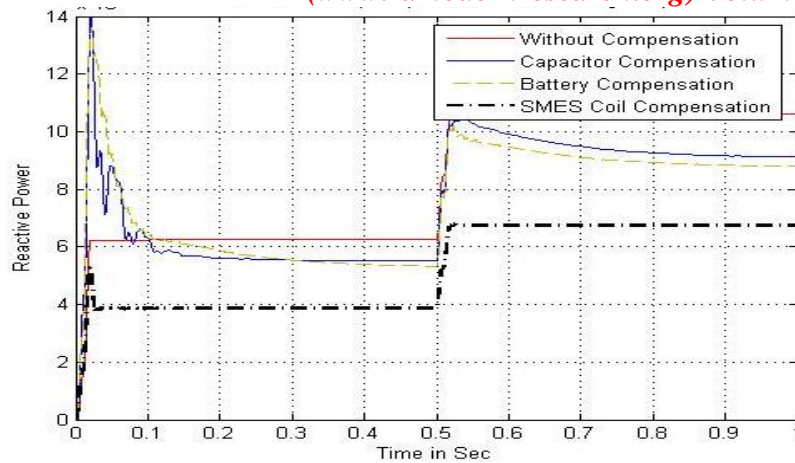
**Figure 9: Active power at sending end with and without STATCOM**



**Figure 10: Reactive power at sending end with and without STATCOM**

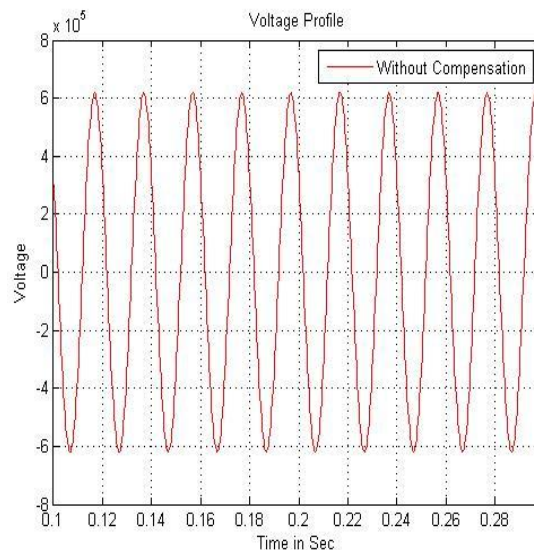


**Figure 11: Active power at receiving end with and without STATCOM**

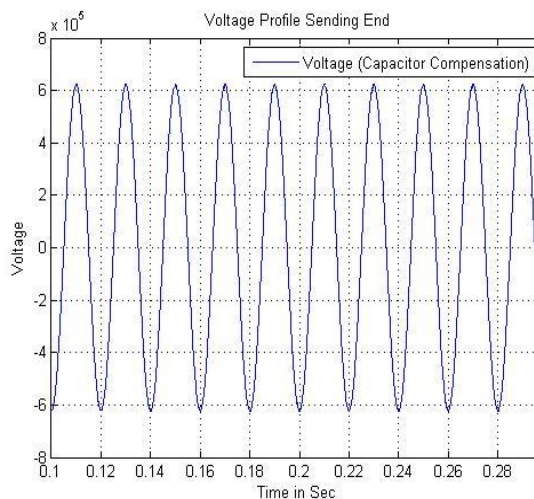


**Figure 12 Reactive power at receiving end with and without STATCOM**

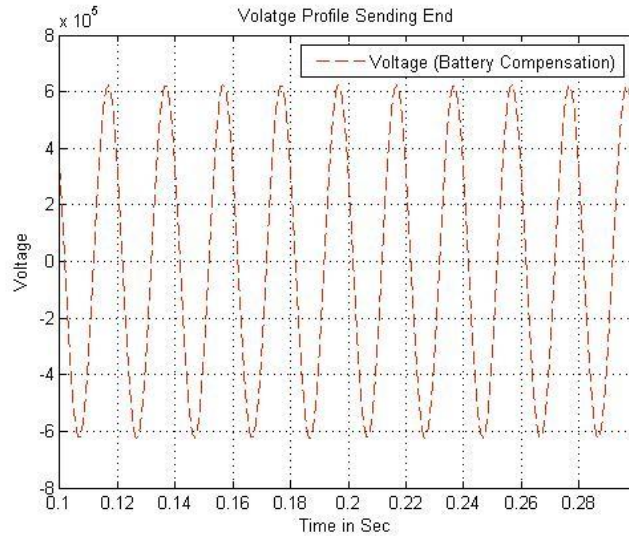
By utilization of load power feed-forward control, the pulsating part of the active power was almost fully provided by the VSC. The network only supply the active power of the load, so no phase shift in bus voltage. The phase jump is reduced due to utilization of the active power compensation, which reduced disturbance to phase sensitive loads.



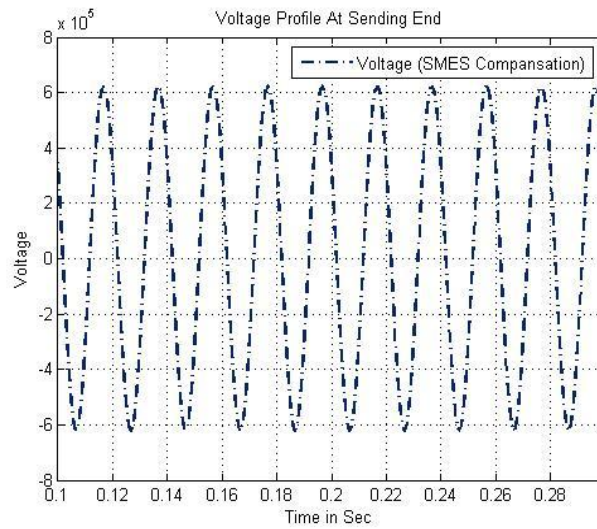
**Figure 13: Voltage at sending end without STATCOM**



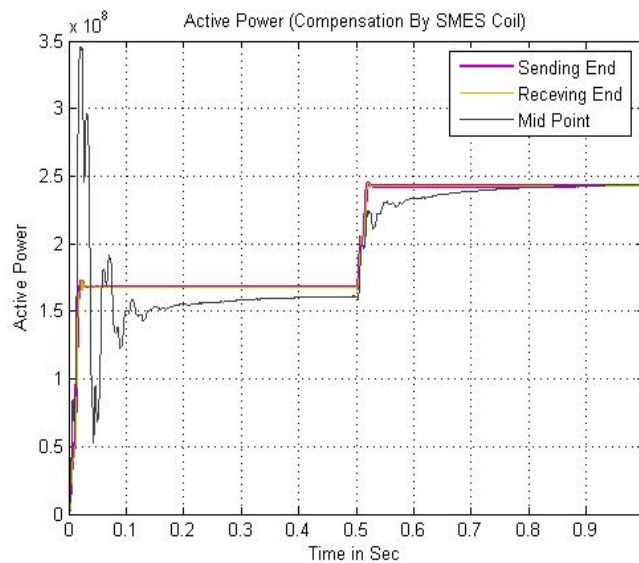
**Figure 14: Voltage at sending end with capacitor**



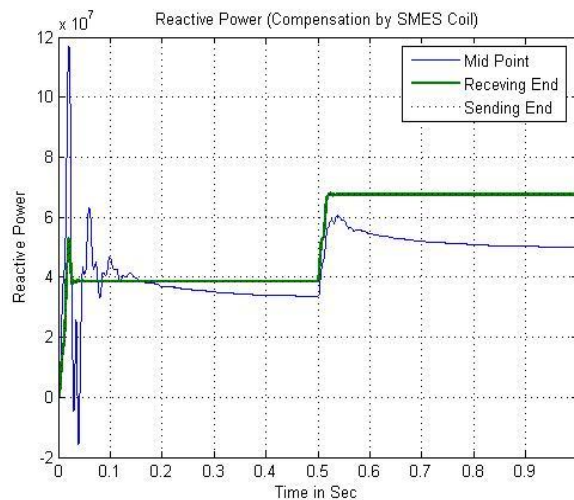
**Figure 15: Voltage at sending end with battery**



**Figure 16: Voltage at sending end SMES coil**



**Figure 17: Optimal location of STATCOM at Midpoint for active power**



**Figure 18: Optimal location of STATCOM at midpoint for Reactive power compensation**

**Table 1: System data without compensation**

Voltage(kv) Peak to Peak		Active power (MW)		Reactive power (Mvar)	
Load 1	Load 2	Load 1	Load 2	Load 1	Load 2
610	612	120	172	62	107

**Table 2: System data with compensation at sending end**

Energy Storage Devices	Voltage(kv) Peak to Peak		Active power (MW)		Reactive power (Mvar)	
	Load 1	Load 2	Load 1	Load 2	Load 1	Load 2
Capacitor	615	617	123	189	60	86
Battery	620	622	133	185	50	83
SMES	622.2	623	134	200	49	80

**Table 3: System data with compensation at midpoint**

Energy storage Devices	Voltage(KV) Peak to Peak		Active power (MW)		Reactive power (Mvar)	
	Load 1	Load 2	Load 1	Load 2	Load 1	Load 2
Capacitor	615	619	125	173	58	84
Battery	621	623	136	189	47	78
SMES	623.1	623.4	140	200	43	73

**Table 4: System data with compensation at receiving end**

Energy storage Devices	Voltage (KV) Peak to Peak		Active power (MW)		Reactive power (Mvar)	
	Load 1	Load 2	Load 1	Load 2	Load 1	Load 2
Capacitor	615	619	125	173	58	84
Battery	621	622	136	189	47	78
SMES	622.4	623	134	200	49	81

In addition to the magnitude disturbance, the pulsating active power also creates phase jumps in the voltage at the PCC, which might degrade the performance of other loads, especially phase sensitive loads, connected at the same point. In order to mitigate the disturbances introduced by the pulsating active load, active power compensation can be utilized if energy storage devices are connected on the dc side of

the converter. In this study, the energy storage device is supposed to be a large capacitor bank, battery and SMES. The coil capacity of the SMES coil is very high than the battery. When the sequence deviation exceeds the dead band limit the SMES device is activated. The rapid active power supply allows to listen impact of the power system disturbance occurred. Avoiding the activation of the load shedding scheme and recovering very quickly the frequency in this way the injection power by the SMES coil as well as the compensation of the active power provided by the STATCOM. The pulsating active power will be mainly exchanged between the cyclic load and the converter, while the network only needs to supply the average active power to the load.

### **7. Conclusions:**

Cyclic loads may create severe disturbances in the power system network. Simulations have shown that a STATCOM/SMES can provide fast reactive power support and thus can stabilize the bus voltage. Integration of energy storage with a STATCOM can further mitigate the voltage magnitude disturbance. Finally the reactive power is reduced and it is conducted that the optimal location of STATCOM integrated with energy storage device in a power system network is midpoint compensation in midpoint compensation.

### **8. References:**

1. Z. Yang, C. Shen, L. Zhang, M. Crow, and S. Atcitty, "Integration of a STATCOM and battery storage," *IEEE Trans. Power Sys.*, vol. 16, no. 2, pp. 254-260, May 2001.
2. K. Kobayashi, M. Goto, K. Wu, Y. Yokomizu and T. Matsumura, "Power system stability improvement by energy storage type STATCOM," in *Proc. IEEE Power Tech Conf.*, 2003.
3. L. Angquist, "Synchronous Voltage Reversal control of Thyristor Controlled Series Capacitor," Ph.D. dissertation, Royal Institute of Technology (KTH), Stockholm, Sweden, 2002.
4. H. Xie, L. Angquist, and H. P. Nee, "Novel flux Modulated Positive and Negative Sequence Deadbeat Current Control of Voltage Source Converters," in *Proc. IEEE Power Engineering Society General Meeting*, 2006.
5. D. Jovicic and K. Kahle, "Compensation of Particle Accelerator Load Using Converter -Controlled Pulse Compensator," *IEEE Trans. on Power Del.*, vol. 21, no. 2, pp. 801-808, April 2006.
6. Arulampalam, J. Ekanayake, and N. Jenkins, "Application Study of a STATCOM with energy storage," in *IEEE Proc.-Gener., Transm., Distrib.*, pp. 373-384.
7. Y. L. Tan, "Analysis of Line Compensation by Shunt-Connected FACTS Controllers: A Comparison between SVC and STATCOM", *IEEE Power Engineering Review*, pp.57-58, August 1999.
8. Z. Chen, F. Blaabjerg, Y Hu, "Voltage Recovery of Dynamic Slip Control Wind Turbines with a STATCOM", *International Power Electronic Conference (IPEC05)*, S29-5, pp.1093-1100, April, 2005.
9. Junji Tamura et al.: "Transient Stability Simulation of Power System Including Wind Generator by PSCAD/EMTDC", *2001 IEEE Porto Power Tech Proceedings*, Vol.4, EMT-108, 2001.
10. Olimpo Anaya-Lara and E. Acha, "Modeling and Analysis of Custom Power System by PSCAD/EMTDC", *IEEE Transaction on Power Delivery*, Vol.17, No. 1, pp.266-272, Jan 2002.